

SUSPENSION AND AXLE

TROUBLESHOOTING

Use the table to help you find the cause of the problem. The numbers indicate the priority of the likely case of the problem. Check each part in order. If necessary, replace these parts.

See page	SA-3	SA-3	SA-3	SA-30, SA-47	SA-51	SA-30, SA-47	SA-37	SA-10, SA-41	-		SA-30, SA-47		
Parts Name	Tires	Cold tire Inflation pressure	Wheel alignment	Springs	Stabilizer bar (Rear axle beam)	Shock absorber	Ball joint	Hub bearings	Steering linkage	Steering gear	Suspension parts	Overloaded	Wheel balance
Trouble													
Wander/pulls	1		2					4	3	5	6		
Bottoming				2		3						1	
Sways/pitches	1				2	3							
Front wheel shimmy	1		4			3	5	6	7	8			2
Abnormal tire wear		1	2			4					3		

GENERAL INSPECTION

SA10X-01

1. INSPECT TIRE

- (a) Check the tires for wear and for the proper inflation pressure.

Cold tire inflation pressure:

Tire size	Front kPa (kg/cm ² , psi)	Rear kPa (kg/cm ² , psi)
P145/80R13	225 (2.25, 32)	225 (2.25, 32)
155SR 13 AS	225 (2.25, 32)	225 (2.25, 32)
P155/80R13 AS	225 (2.25, 32)	225 (2.25, 32)

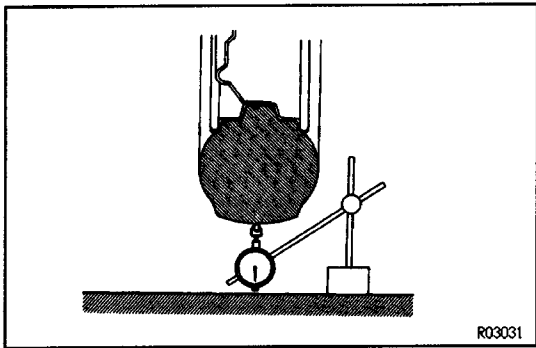

- (b) Check the tire runout.

Tire runout:

Less than 1.4 mm (0.055 in.)

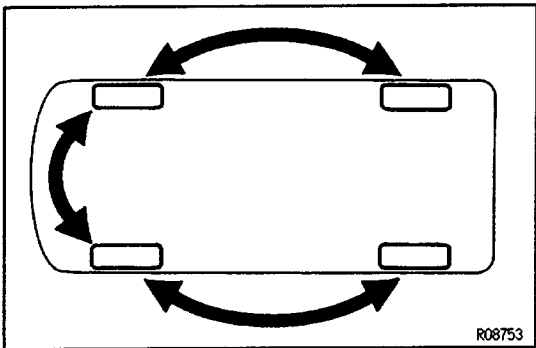

2. ROTATING TIRES

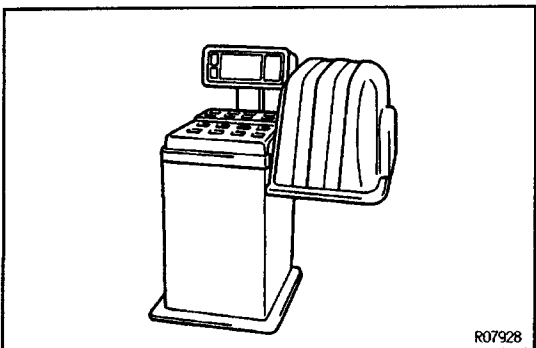

3. INSPECT WHEEL BALANCE

- (a) Check and adjust the Off-the-car-balance.
- (b) If necessary, check and adjust the On-the-car-balance.

Unbalance after adjustment:

8.0 g (0.018 lb) or less

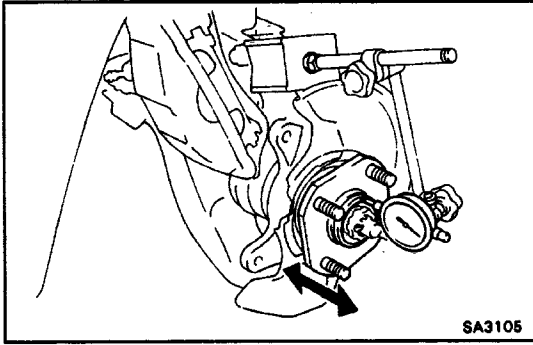

4. CHECK WHEEL BEARING LOOSENESS

(a) Check the backlash in bearing shaft direction.

Maximum:

0.05 mm (0.0020 in.)

(b) Check the axle hub deviation.

Maximum:

0.05 mm (0.0020 in.)

5. CHECK SUSPENSION FOR LOOSENESS

6. CHECK STEERING LINKAGE FOR LOOSENESS

7. CHECK BALL JOINT FOR EXCESSIVE LOOSENESS

8. CHECK SHOCK ABSORBER WORK PROPERLY

- Check for oil leak
- Check mounting bushings for wear
- Bounce front and rear of the vehicle

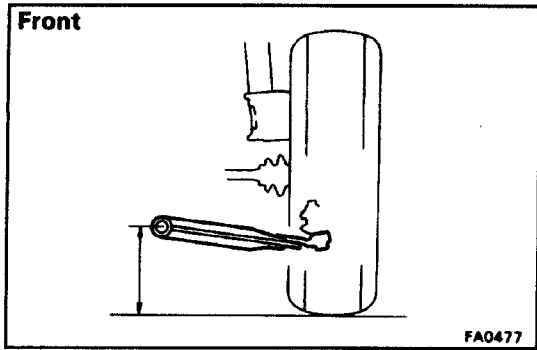

WHEEL ALIGNMENT

FRONT WHEEL ALIGNMENT

SA172-01

1. MEASURE VEHICLE HEIGHT

Front vehicle height:

Tire size	Front
P145/80R13	185 mm (7.28 in.)
155SR13 AS	192 mm (7.56 in.)
P 155/80R13 AS	192 mm (7.56 in.)

Measuring point:

Front:

Measure from the ground to the center of the lower suspension arm front mounting bolt.

NOTICE: Before inspecting the wheel alignment, adjust the vehicle height to specification.

If the vehicle height is not standard, try to adjust it by pushing down on or lifting the body.

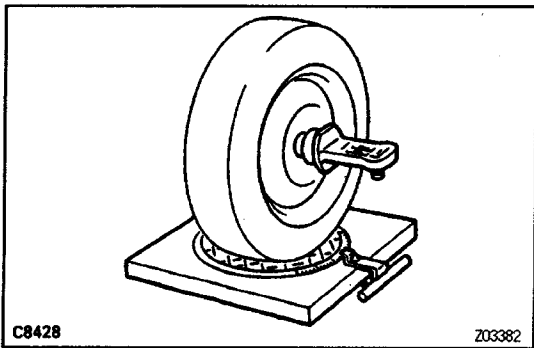

2. INSTALL CAMBER-CASTER- KINGPIN GAUGE OR ONTO WHEEL ALIGNMENT TESTER

Follow the specific instruction of the equipment manufacturer.

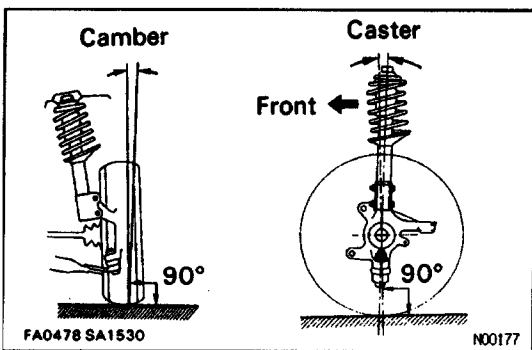

3. INSPECT CAMBER, CASTER AND STEERING AXIS INCLINATION

Specifications:

Camber		-0° 15' + 45'
	Left-right error	45' or less
Caster		1° 15' + 45'
	Left-right error	45' or less
Steering axis inclination		12° 00' + 45'
	Left-right error	45' or less

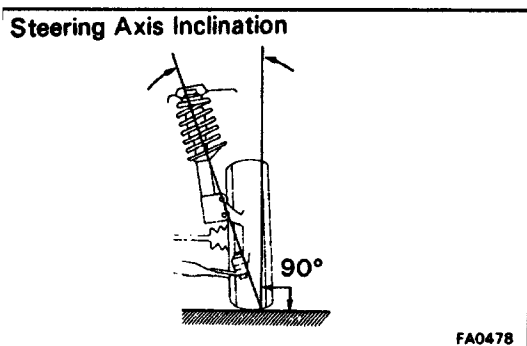

HINT: Camber, caster and steering axis inclination are not adjustable, if measurements are not within specification, inspect and replace the suspension parts as necessary.

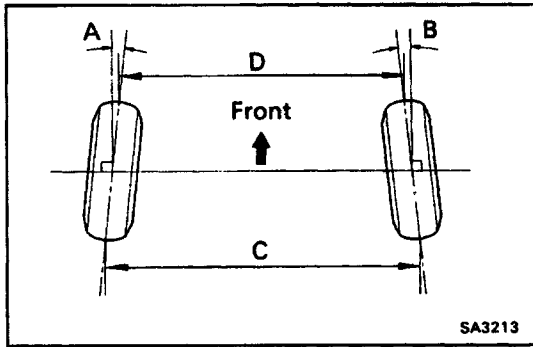

4. INSPECT TOE-IN

Toe-in (total):

$$A + B \ 0.1^\circ \pm 0.2^\circ$$

$$C - D \ 1 \pm 2 \text{ mm } (0.04 \pm 0.08 \text{ in.})$$

If toe-in is not within specification adjust by the tie rod end.

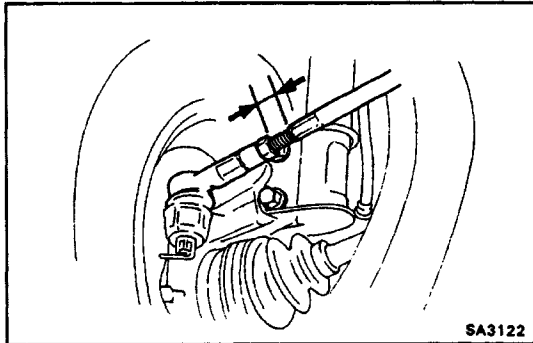

5. ADJUST TOE-IN

- (a) Remove the boot clamps.
- (b) Loosen the tie rod end lock nuts.
- (c) Turn the left and right tie rod ends an amount to adjust the toe-in.

Toe-in (total):

$$A + B \ 0.10 \pm 0.10$$

$$C - D \ 1 \pm 1 \text{ mm } (0.04 \pm 0.04 \text{ in.})$$

HINT: Measure that the lengths of the left and right tie rods length are the same.

Tie rod end length left-right error:

Less than 1.5 mm (0.059 in.)

- (d) Tighten the tie rod end lock nut.

Torque: 47 N-m (480 kgf-cm, 35 ft-lbf)

- (e) Place the the boot on the seat and clip it.

HINT: Make sure that the boots are not twisted.

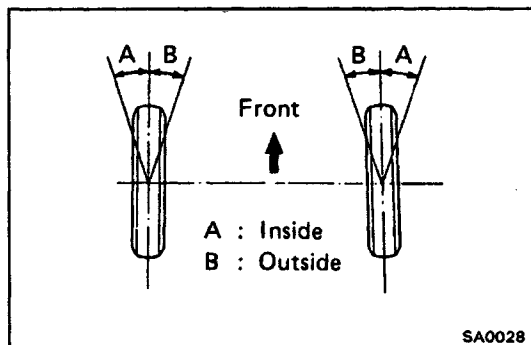

5. INSPECT WHEEL ANGLE

Wheel angle:

Inside wheel	$36^\circ 10' \pm 2^\circ$
Outside wheel (reference)	$32^\circ 15'$

If wheel angles differ from the standard specifications, inspect the toe-in.

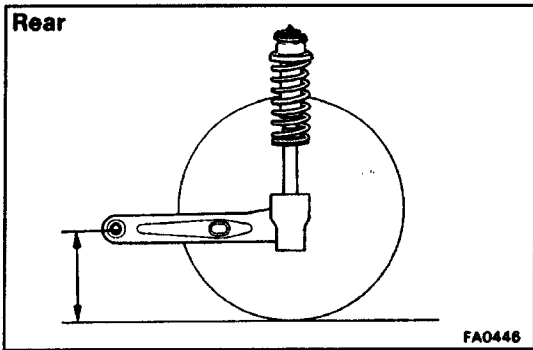

REAR WHEEL ALIGNMENT.

1. MEASURE VEHICLE HEIGHT

SA178-01

Rear vehicle height:

Tire size	Rear
P145/80R13	248 mm (9.76 in.)
155SR13 AS	255 mm (10.03 in.)
P155/80R13 AS	255 mm (10.03 in.)

Measuring point:

Rear:

Measure from the ground to the center of the strut rod mounting bolt.

NOTICE: Before inspecting the wheel alignment, adjust the vehicle height to specification.

If the vehicle height is not standard, try to adjust it by pushing down on or lifting the body.

2. INSPECT CAMBER

Camber:

Camber	Left-right error	- 0° 30' ± 45' 45' or less
--------	------------------	-------------------------------

HINT: Camber is not adjustable, if measurement is not within specification, inspect and replace the suspension parts as necessary.

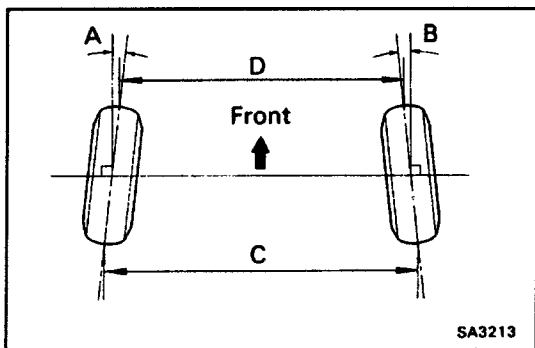

3. INSPECT TOE-IN

Toe- in (total):

A + B 0.30 + 0.30

C-D 3+3mm(0.12+0.12in.)

HINT: Toe-in is not adjustable, if measurement is not within specification, inspect and replace the suspension parts as necessary.

FRONT AXLE

DESCRIPTION

The wheel bearings are double-row angular ball bearings having small rolling resistance and are free from maintenance.

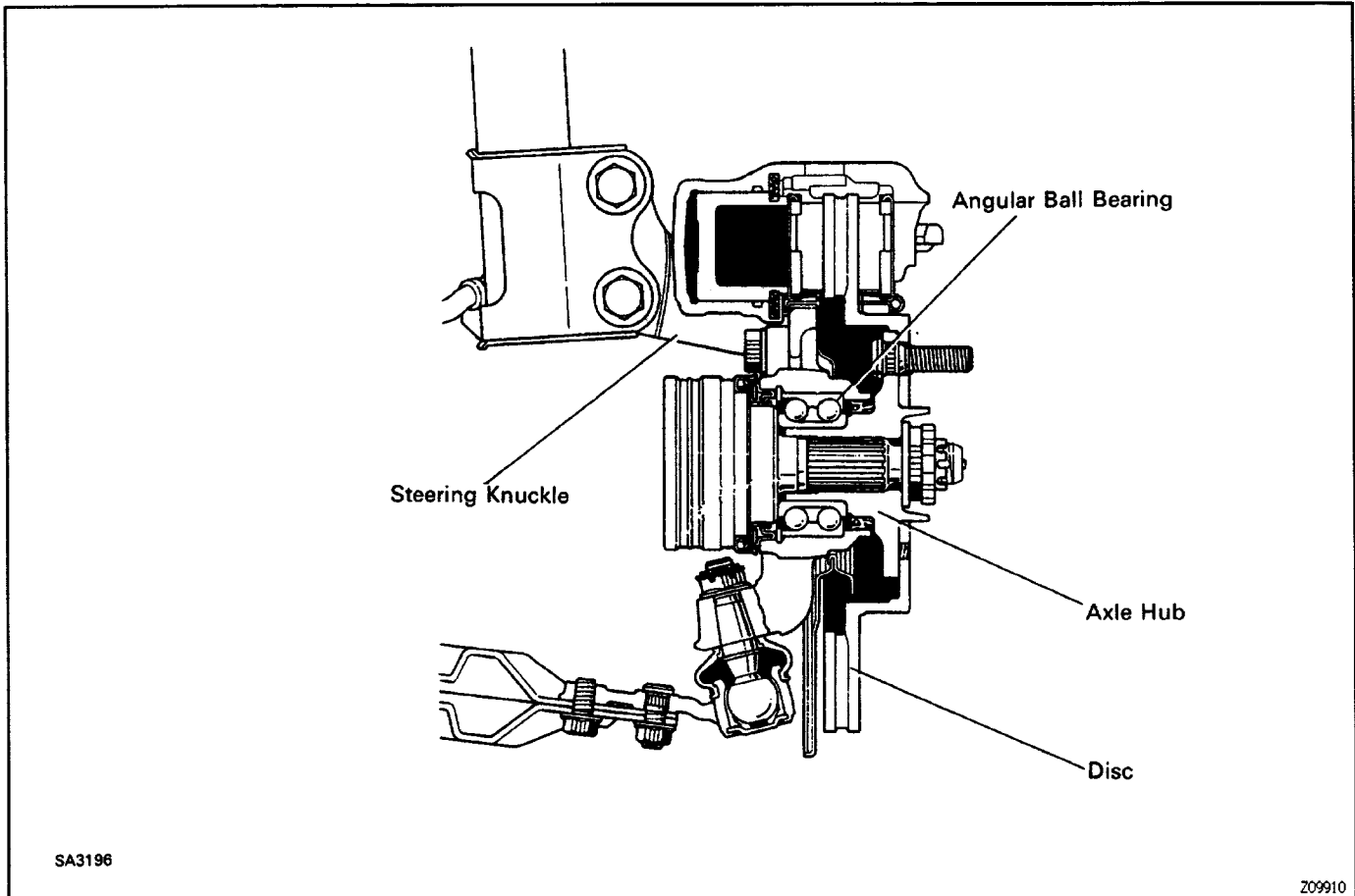

The preload of the bearing can be determined only tightening the drive shaft nut at a specified torque, improving serviceability.



PREPARATION

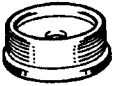
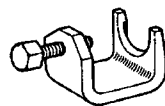
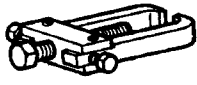

SA00K-01

SST(SPECIAL SERVICE TOOLS)

	09308-00010 Oil Seal Puller	Steering knuckle oil seal
	09608-10010 Steering Knuckle Oil Seal Replacer	
	09628-10011 Ball Joint Puller	Replacement of hub bolt
	09628-62011 Ball Joint Pulier	
	09950-20017 Universal Puller	

RECOMMENDED TOOLS

SA00L-01

	09042-00010 Tom Socket T30	Dust cover set bolt
	09905-00013 Snap Ring Pliers	Front axle hub bearing

SA00M-01

EQUIPMENT

Dial indicator	
Torque wrench	

FRONT AXLE HUB COMPONENTS

SA603-0A

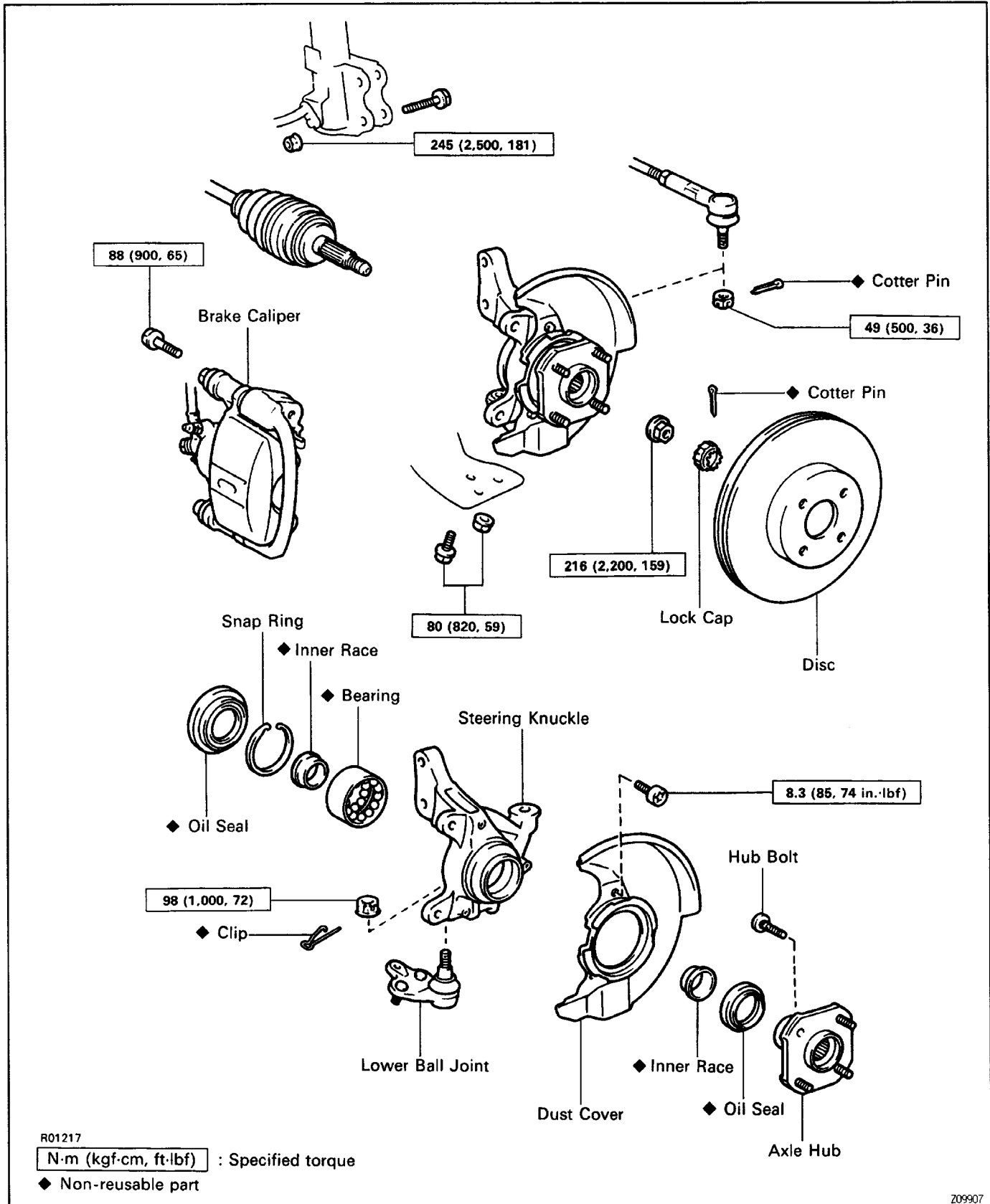

R01217

N·m (kgf·cm, ft·lbf) : Specified torque

◆ Non-reusable part

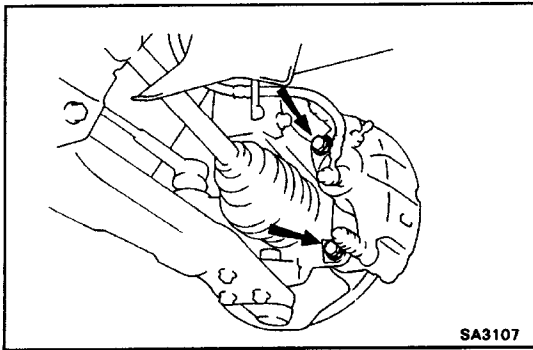

STEERING KNUCKLE WITH AXLE HUB REMOVAL

1. JACK UP VEHICLE, REMOVE FRONT WHEEL
2. REMOVE FRONT BRAKE CALIPER AND DISC

- (a) Remove the 2 bolts and remove the brake caliper from the steering knuckle.
- (b) Hang up the brake caliper using wire, etc.
- (c) Remove the disc.

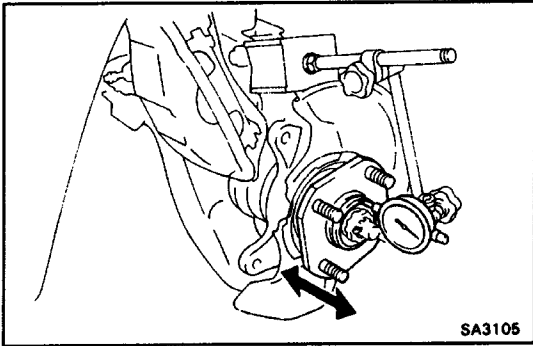

3. CHECK BACKLASH IN BEARING SHAFT DIRECTION

Place a dial indicator near the center of the axle hub and check the backlash in the bearing shaft direction.

Maximum:

0.05 mm (0.0020 in.)

If greater than the specified maximum, replace the bearing.

4. CHECK AXLE HUB DEVIATION

Using a dial indicator, check the deviation at the surface of the axle hub outside the hub bolt.

Maximum:

0.05 mm (0.0020 in.)

If greater than the specified maximum, replace the hub bolt.

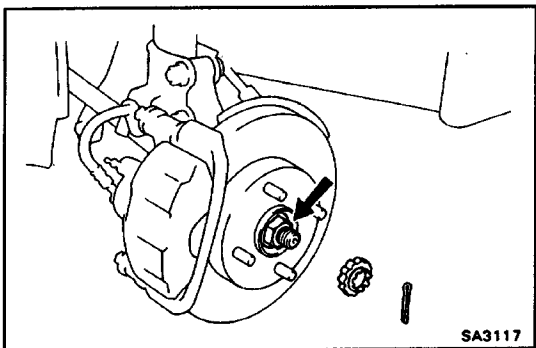

5. REMOVE DRIVE SHAFT LOCK NUT

- (a) Install the disc and brake caliper.
- (b) Remove the cotter pin and lock cap.
- (c) While applying the brakes, remove the nut.
- (d) Remove the brake caliper and disc.

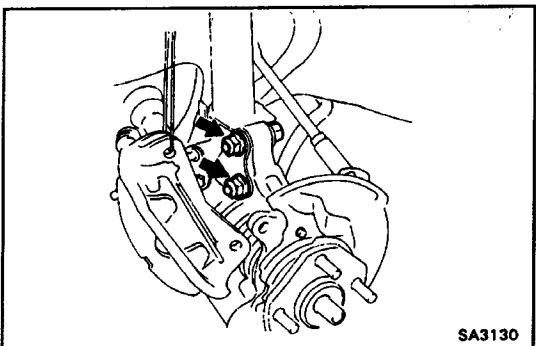

6. LOOSEN NUTS ON LOWER SIDE OF SHOCK ABSORBER

HINT: Do not remove the 2 bolts.

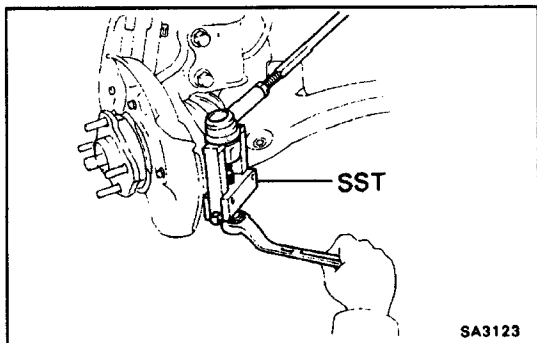

7. DISCONNECT TIE ROD END FROM STEERING KNUCKLE

- (a) Remove the cotter pin and remove the nut.
- (b) Using SST, disconnect the tie rod end from the steering knuckle.
SST 09628-62011

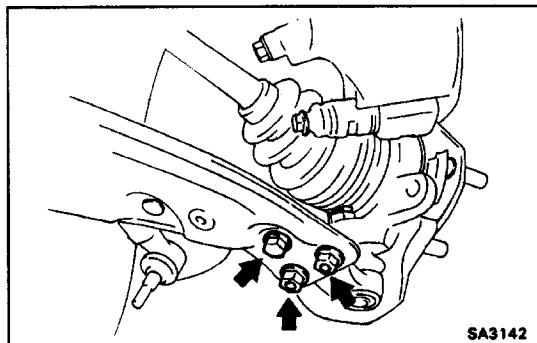

8. DISCONNECT LOWER BALL JOINT FROM LOWER ARM

Remove the bolt and the 2 nuts.

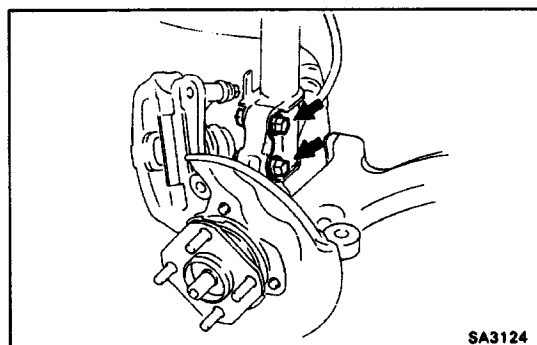

9. REMOVE STEERING KNUCKLE WITH AXLE HUB

- (a) Remove the 2 nuts and bolts on lower side of the shock absorber.

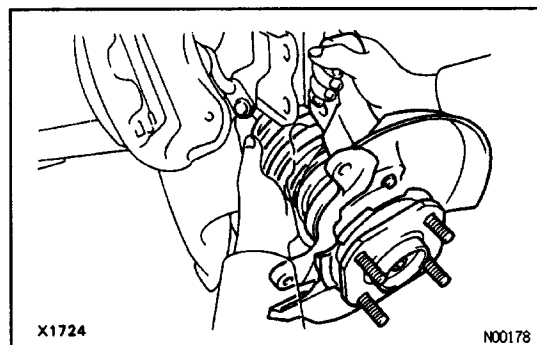

- (b) Remove the steering knuckle with the axle hub.
NOTICE: Be careful not to damage the oil seal with drive shaft.

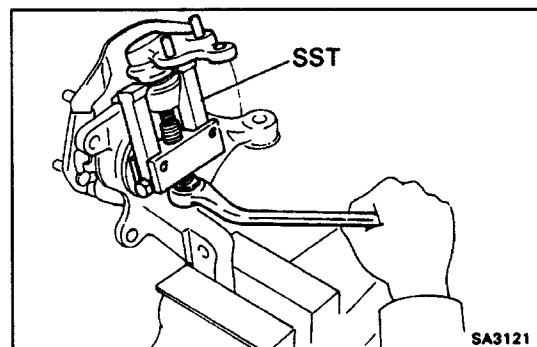

FRONT AXLE HUB DISASSEMBLY

8A00P-05

1. REMOVE LOWER BALL JOINT

- (a) Remove the clip and nut.
- (b) Using SST, remove the lower ball joint.
SST 09628-62011

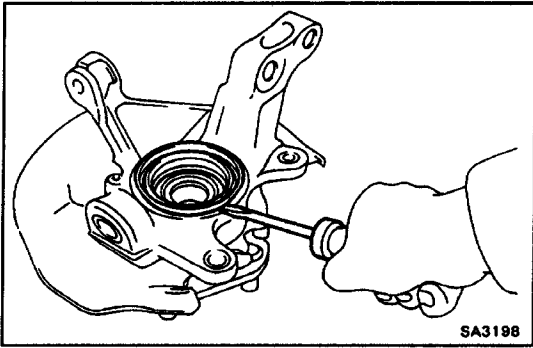

2. REMOVE INNER OIL SEAL

Using a screwdriver, remove the inner oil seal.

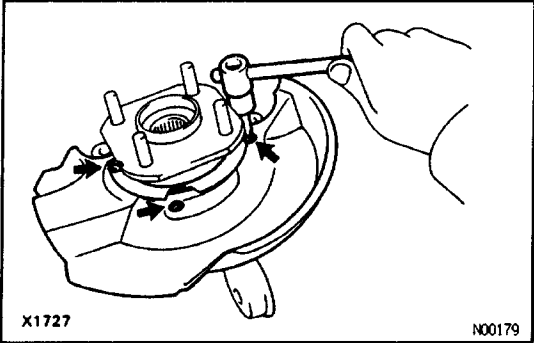

3. REMOVE DUST COVER SET BOLTS

Using a torx wrench, remove the 3 bolts.

Torx wrench: T30 (Part No.09042-00010 or locally manufactured tool)

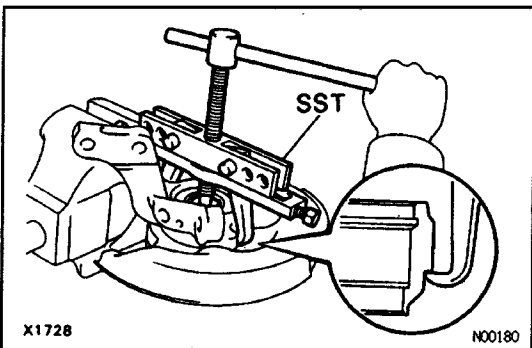

4. REMOVE AXLE HUB AND DUST COVER

(a) Using SST, remove the axle hub from the steering knuckle.

SST 09950-20017

(b) Remove the dust cover.

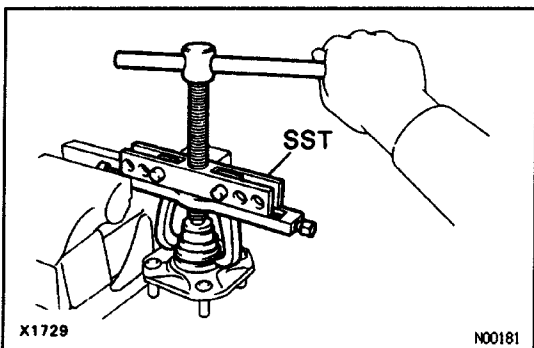

5. REMOVE INNER RACE (OUTSIDE) FROM AXLE HUB

Using SST, remove the inner race from the axle hub.

SST 09950-20017

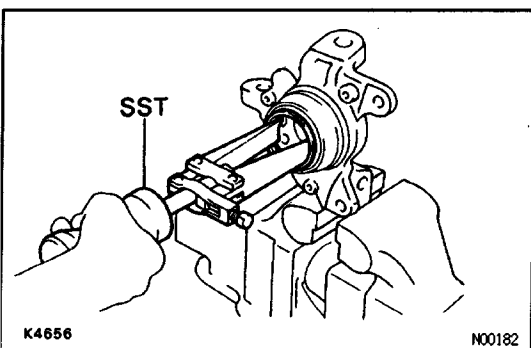

6. REMOVE OUTER OIL SEAL

Using SST, remove the outer oil seal.

SST 09308 - 00010

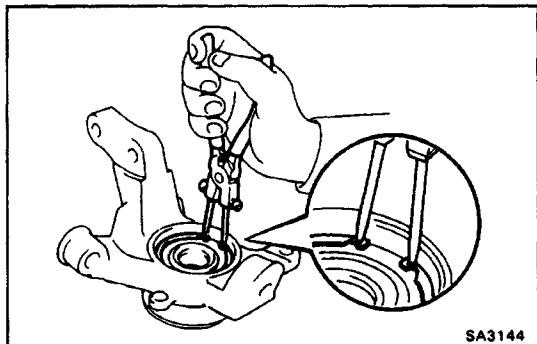

7. REMOVE BEARING FROM STEERING KNUCKLE

(a) Using snap ring pliers, remove the snap ring.

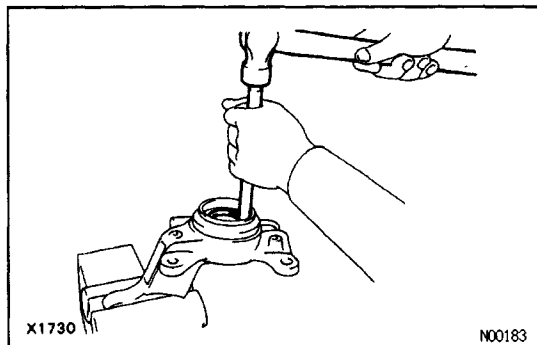

(b) Place the inner race on the outside of the bearing.

(c) Using a brass bar and a hammer, remove the bearing from the steering knuckle.

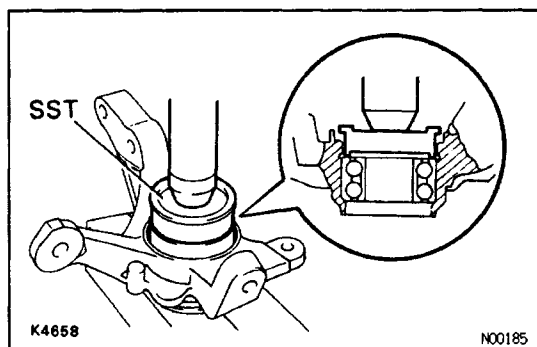

FRONT AXLE HUB ASSEMBLY

SA000-06

1. INSTALL BEARING

(a) Using SST and a press, install a new bearing to the steering knuckle.

SST 09608-10010

NOTICE: If the inner race and balls come loose from the bearing outer race, be sure to install them on the same side as before.

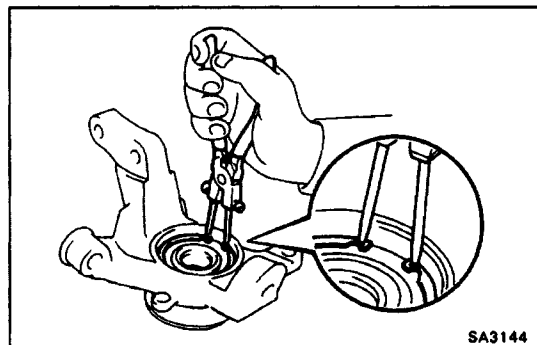

(b) Using snap ring pliers, install the snap ring.

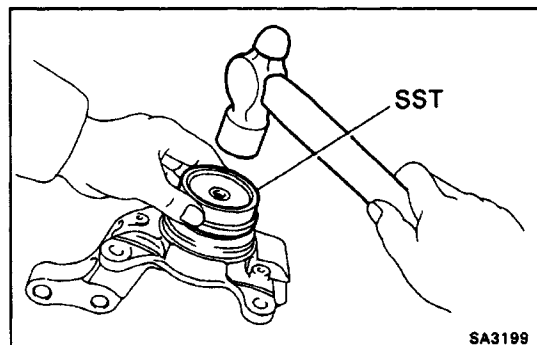

2. INSTALL OUTER OIL SEAL

Using SST and a hammer, install a new outer oil seal.
SST 09608 -10010

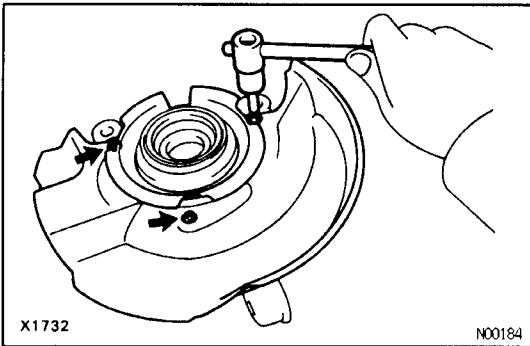

3. INSTALL DUST COVER

- (a) Place the dust cover on the steering knuckle.
- (b) Using a torx wrench, tighten the 3 bolts.,
Torx wrench: T30 Part No. 09042-00010 or locally manufactured tool)

Torque: 8.3 N-m (85 kgf-cm, 74 in.-lbf)

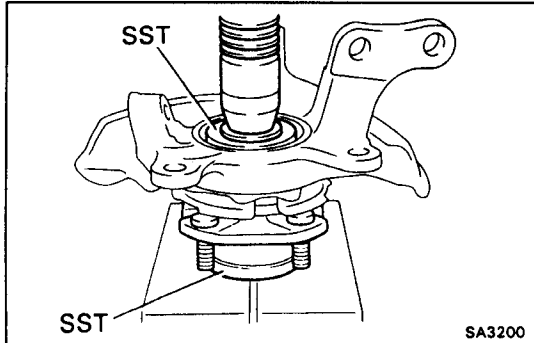

4. INSTALL AXLE HUB

Using SST and a press, install the axle hub.
SST 09608-10010, 09950-20017

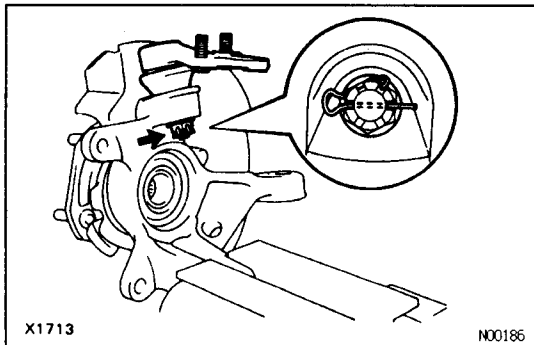

5. INSTALL LOWER BALL JOINT

- (a) Install the lower ball joint and tighten the nut.
Torque: 98 N-m (1.000 kgf-cm, 72 ft-lbf)
- (b) Install a new clip.

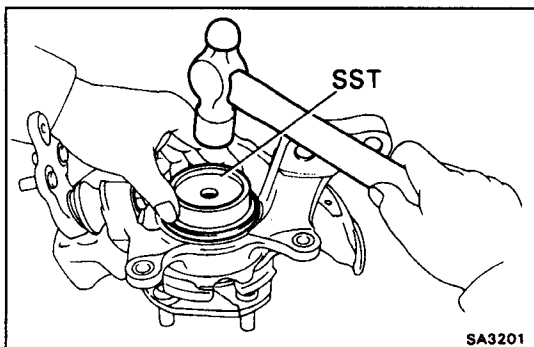

6. INSTALL INNER OIL SEAL

Using SST and a hammer, install a new inner oil seal.
SST 09608 -10010

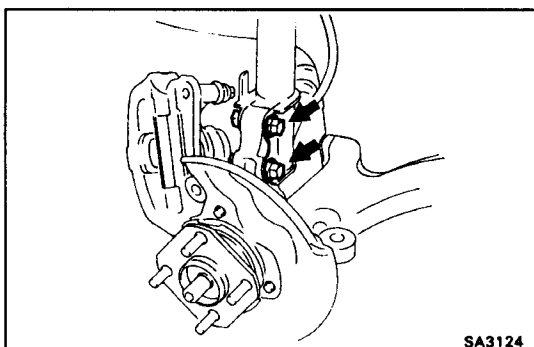

STEERING KNUCKLE WITH AXLE HUB INSTALLATION

1. INSTALL STEERING KNUCKLE

- (a) Place the steering knuckle and temporarily install the 2 bolts and 2 nuts on lower side of shock absorber.

NOTICE: Be careful not to damage the inner oil seal.

HINT: Coat the threads of bolt with engine oil.

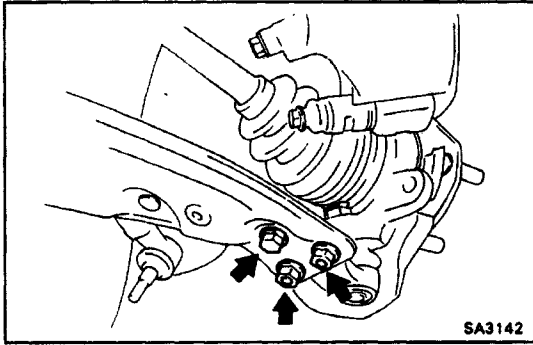

- (b) Connect the lower ball joint to the lower arm and tighten the bolt and 2 nuts.
Torque: 80 N-m (820 kgf-cm, 59 ft-lbf)

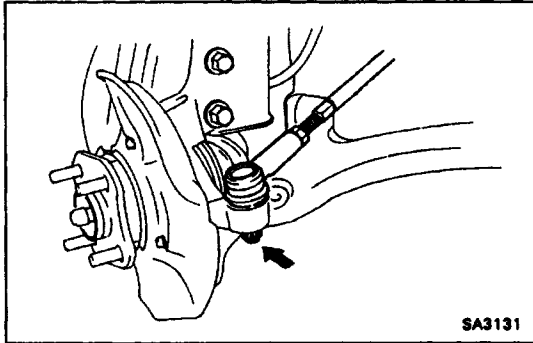

2. CONNECT TIE ROD END TO STEERING KNUCKLE

- (a) Connect the tie rod end to the steering knuckle and tighten the nut.
Torque: 49 N-m (500 kgf-cm, 36 ft-lbf)
 (b) Install a new cotter pin.

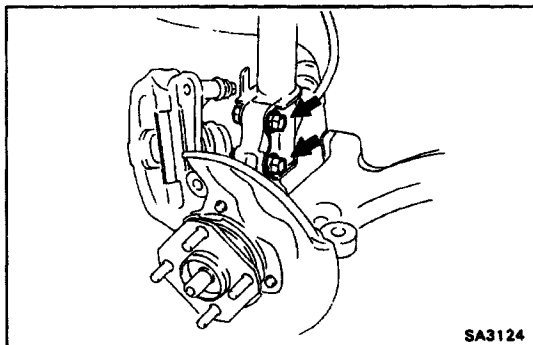

3. TORQUE 2 NUTS ON LOWER SIDE OF SHOCK ABSORBER

- Torque: 245 N-m (2,500 kgf-cm, 181 ft-lbf)**

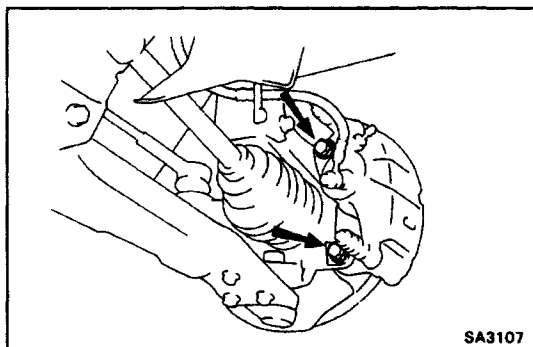

4. INSTALL FRONT BRAKE DISC AND CALIPER

- (a) Place the disc rotor.
 (b) Install the brake cylinder and tighten the 2 bolts.
Torque: 88 N-m (900 kgf-cm, 65 ft-lbf)

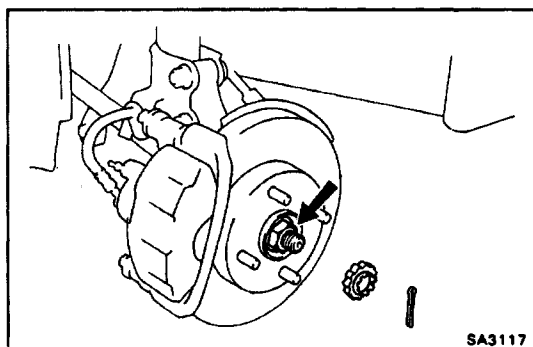

5. INSTALL DRIVE SHAFT LOCK NUT

- (a) While applying the brakes, torque the lock nut.
Torque: 216 N-m (2,200 kgf-cm, 159 ft-lbf)
 (b) install the lock cap and a new cotter pin.

6. INSTALL FRONT WHEEL AND LOWER VEHICLE

Torque: 103 N-m (1,050 kgf-cm, 76 ft-lbf)

7. INSPECT FRONT WHEEL ALIGNMENT

(SEE PAGE SA-5)

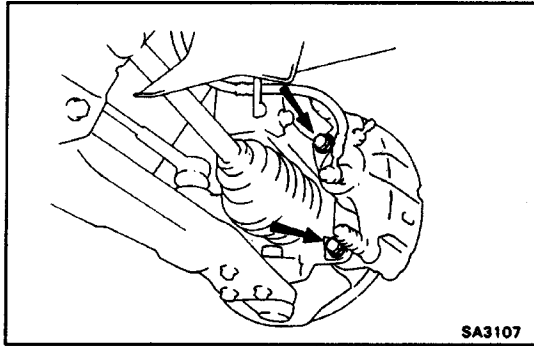
**HUB BOLT REPLACEMENT**

SA008-06

1. JACK UP VEHICLE AND REMOVE FRONT WHEEL**2. REMOVE FRONT BRAKE CALIPER AND DISC**

(See page SA-11)

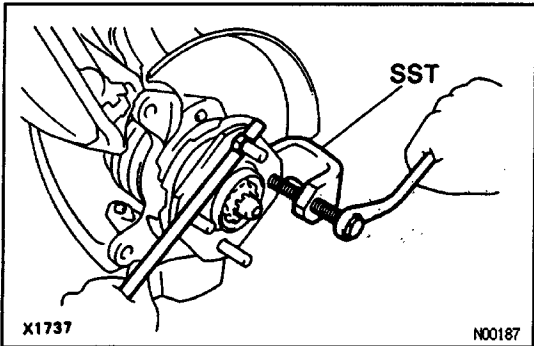
**3. REMOVE HUB BOLT**

Using SST, remove the hub bolt.

SST 09628 -10011

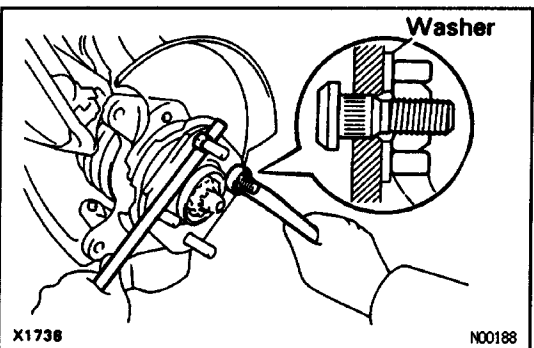
**4. INSTALL HUB BOLT**

Install washer and nut to the hub bolt, as shown in the illustration, and install the hub bolt with torquing the nut.

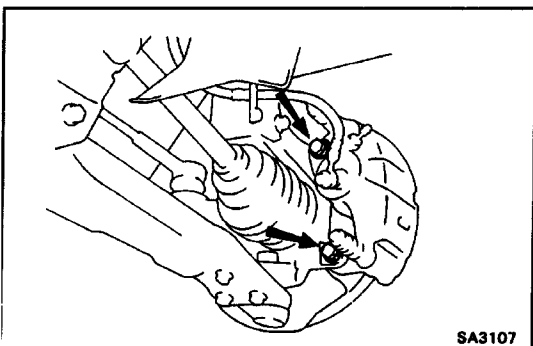
**5. INSTALL FRONT BRAKE DISC AND BRAKE CALIPER**

(See page SA-16)

6. INSTALL FRONT WHEEL AND LOWER VEHICLE

Torque: 103 N-m (1,050 kgf-cm, 76 ft-lbf)

FRONT DRIVE SHAFT

DESCRIPTION

The front drive shaft has a slidable tripod type CVJ (Constant Velocity Joint) on the differential side and Rzeppa type CVJ on the wheel side.

A dynamic damper has been mounted on the right-hand drive shaft to reduce vibration and noise.

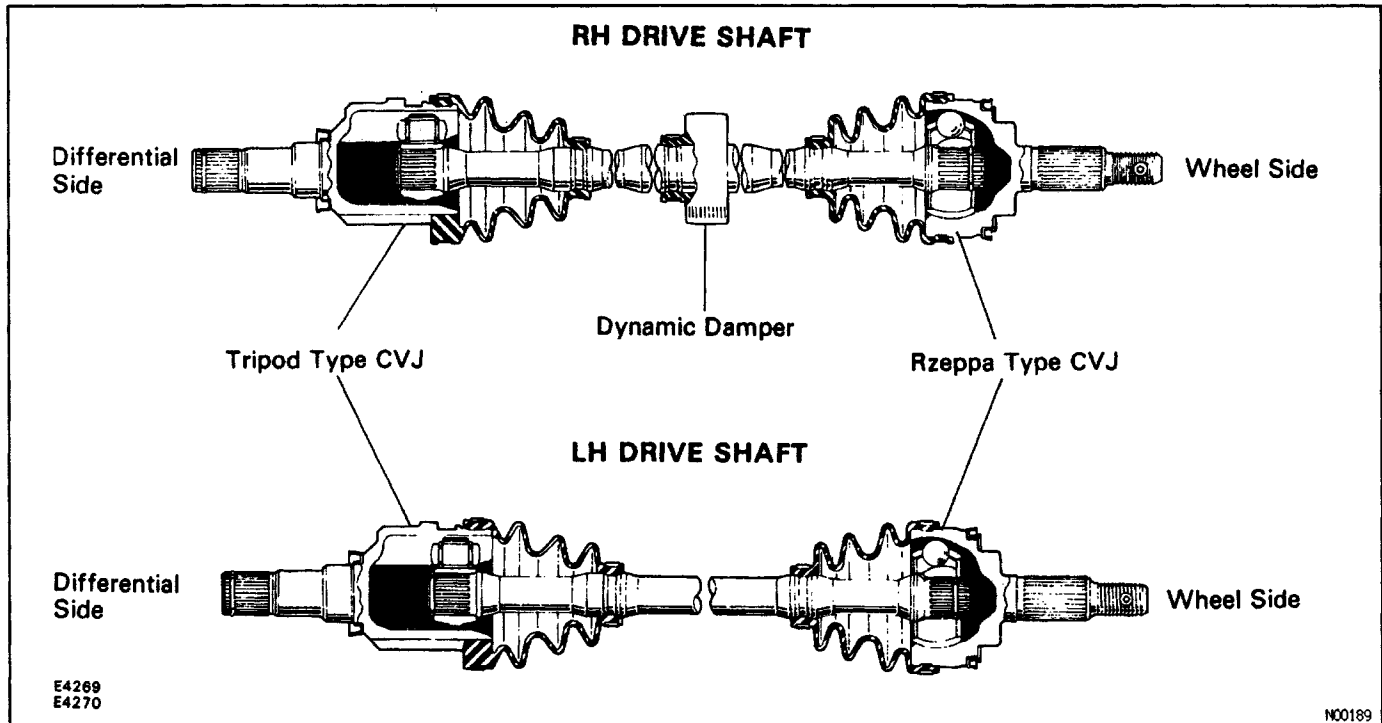

PREPARATION

SST(SPECIAL SERVICE TOOLS)

SA005-01

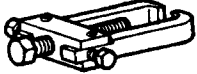
	09628-6201 1 Ball Joint Puller	
---	--------------------------------	--

RECOMMENDED TOOLS

SA006-01

	09905-00012 Snap Ring No. 1 Expander	For removing and installing snap ring
---	--------------------------------------	---------------------------------------

LUBRICANT

SA02H-08

Item	Capacity	Classification
Outboard joint grease	120-130 g (0.26-0.29 lb, 4.9-4.6 oz.)	
Inboard joint grease	140-150 g (0.31 -0.33 lb, 4.9-5.3 oz.)	

FRONT DRIVE SHAFT COMPONENTS

8A007-01

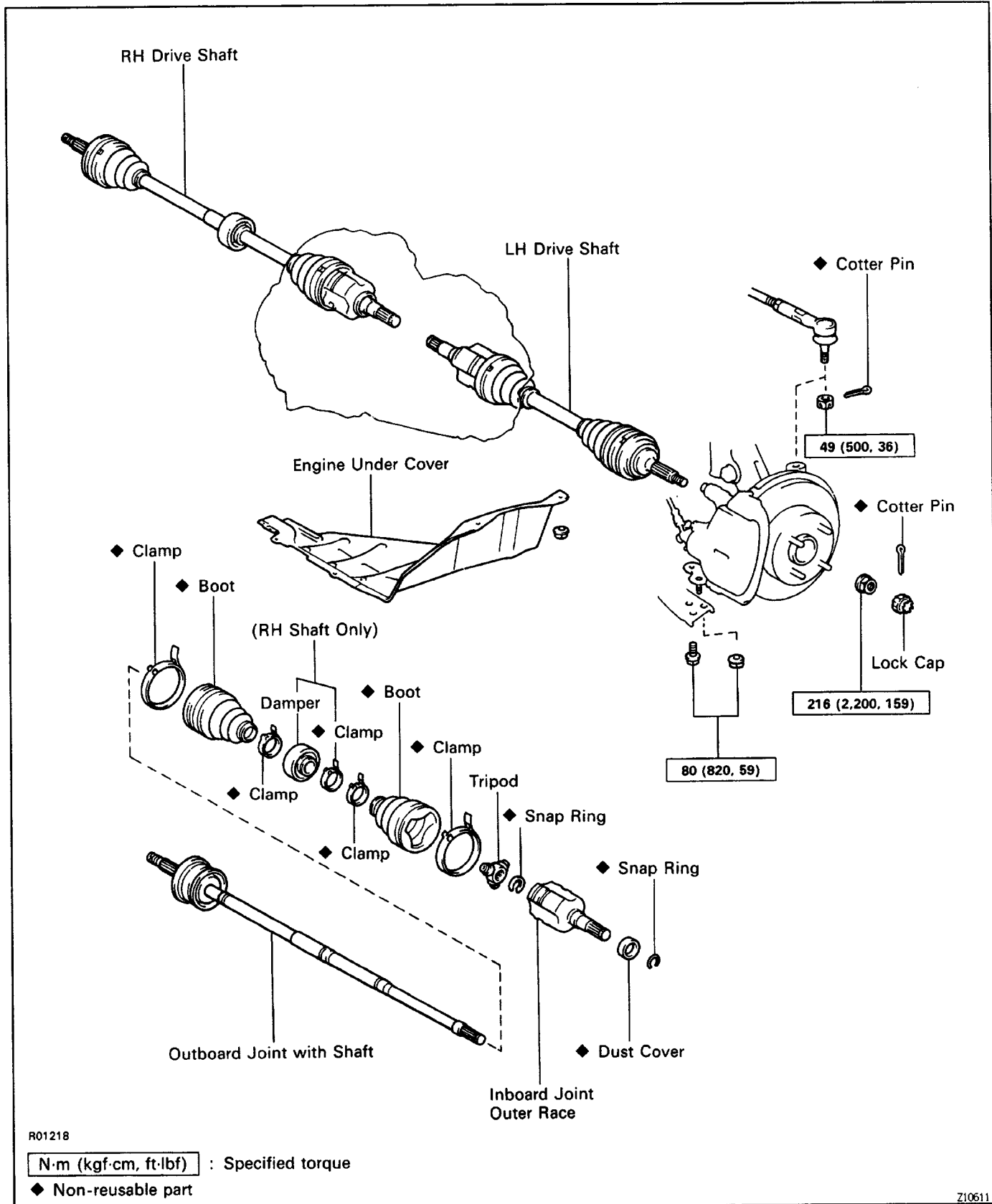

R01218

N·m (kgf·cm, ft·lbf) : Specified torque

◆ Non-reusable part

Z10611

FRONT DRIVE SHAFT REMOVAL

SA007-08

1. JACK UP VEHICLE AND REMOVE FRONT WHEEL

2. MX:

REMOVE LH ENGINE UNDER COVER

3. MX:

DRAIN TRANCE AXLE OIL

AX:

DRAIN ATF

4. REMOVE DRIVE SHAFT LOCK NUT

(a) Remove the cotter pin and lock cap.

(b) While applying the brakes, remove the nut.

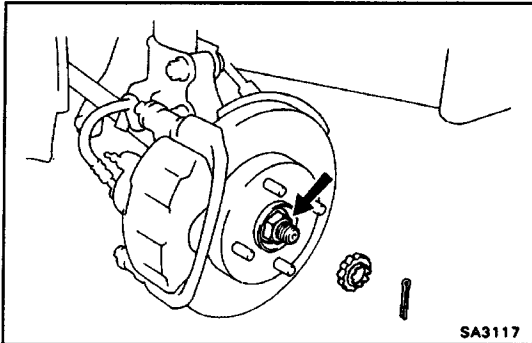

5. DISCONNECT TIE ROD END FROM STEERING KNUCKLE

(a) Remove the cotter pin and nut.

(b) Using SST, disconnect the tie rod end from the steering knuckle.

SST 09628-62011,

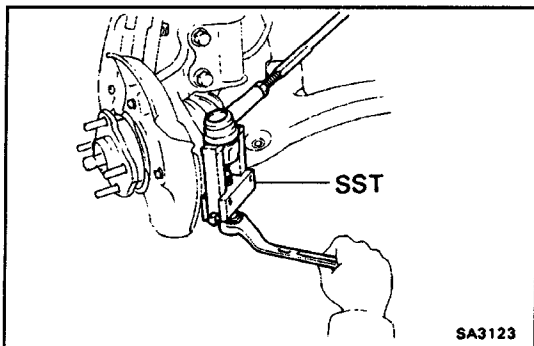

6. DISCONNECT LOWER BALL JOINT FROM LOWER ARM

Remove the bolt and the 2 nuts.

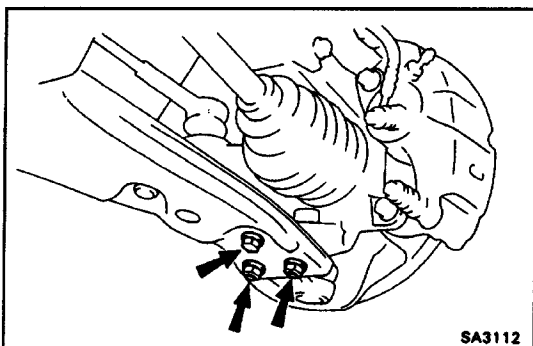

7. DISCONNECT DRIVE SHAFT FROM AXLE HUB

NOTICE: Be careful not to damage the drive shaft boot and inner oil seal.

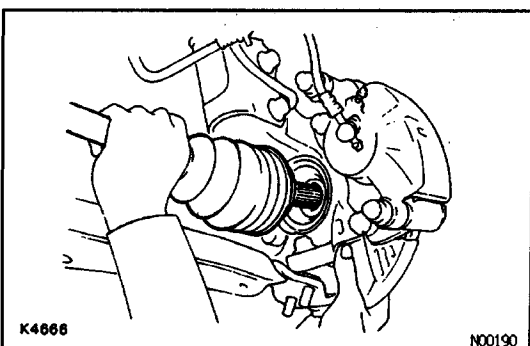

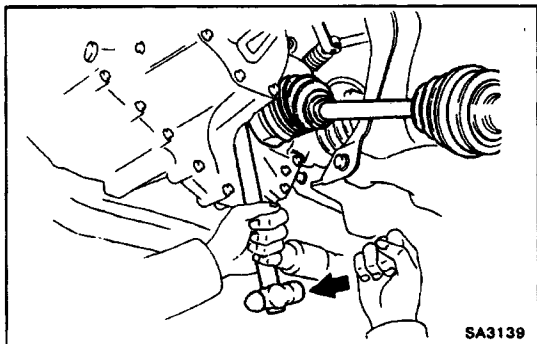
**8. REMOVE DRIVE SHAFT****[LH DRIVE SHAFT]****Mx:**

Using a hammer, remove the drive shaft.

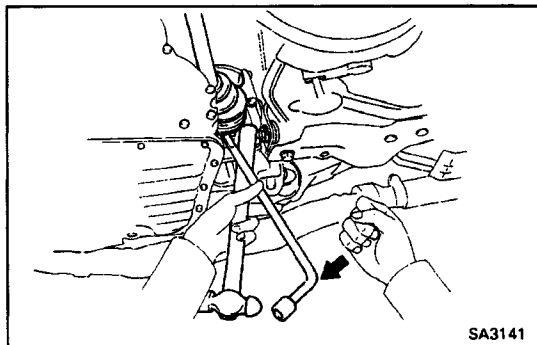
**AX:**

Using a hammer and a hub nut wrench or an equivalent, remove the drive shaft.

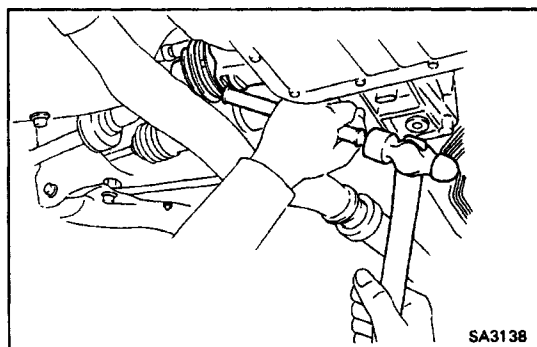
**[RH DRIVE SHAFT]**

Using a brass bar and a hammer, tap out the drive shaft.

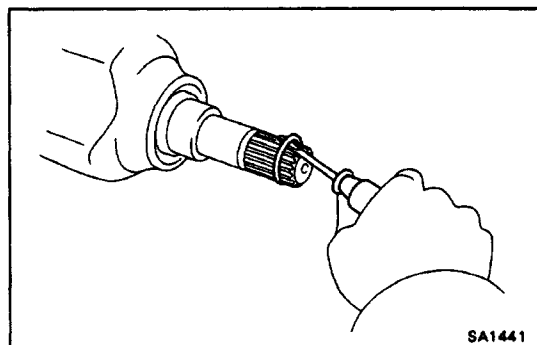
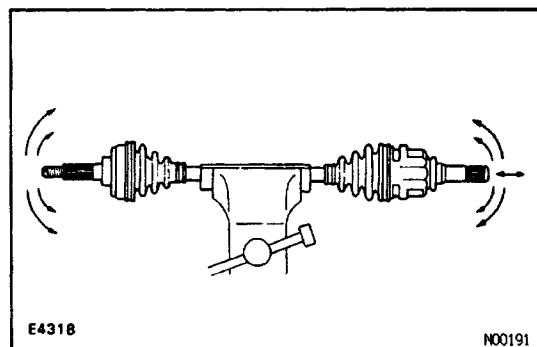
**9. REMOVE SNAP RING****FRONT DRIVE SHAFT DISASSEMBLY****1. CHECK DRIVE SHAFT**

- (a) Check to see that there is no play in the outboard joint.
- (b) Check to see that the inboard joint slides smoothly in the thrust direction.
- (c) Check to see that there is no remarkable play in the radial direction of the inboard joint.

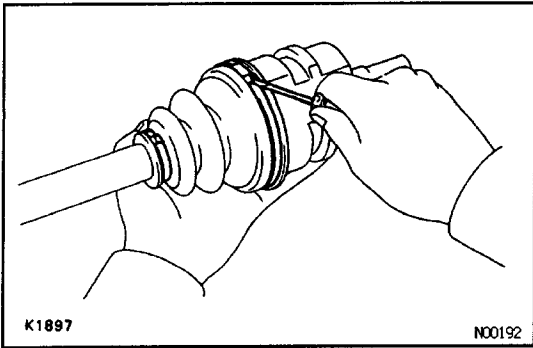

2. REMOVE INBOARD JOINT BOOT CLAMPS

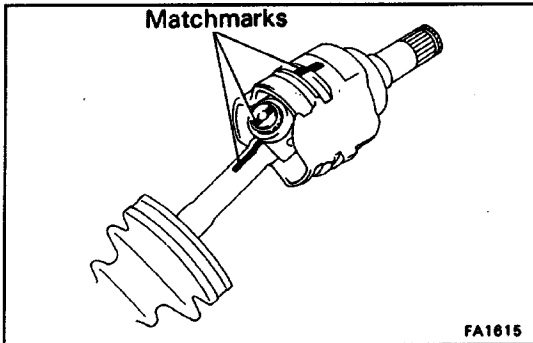

3. REMOVE INBOARD JOINT BOOT TULIP

- (a) Place matchmarks on the inboard joint tulip and tripod.

NOTICE: Do not punch the marks.

- (b) Remove the inboard joint tulip from the drive shaft.

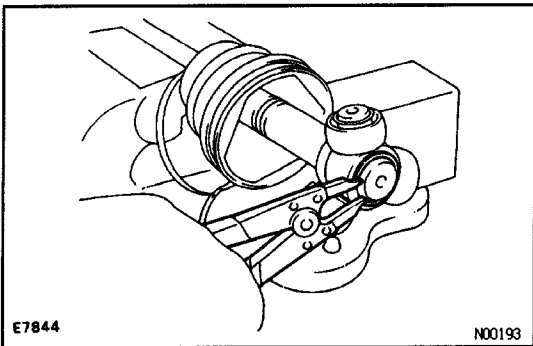

4. REMOVE TRIPOD JOINT

- (a) Using a snap ring expander, remove the snap ring.

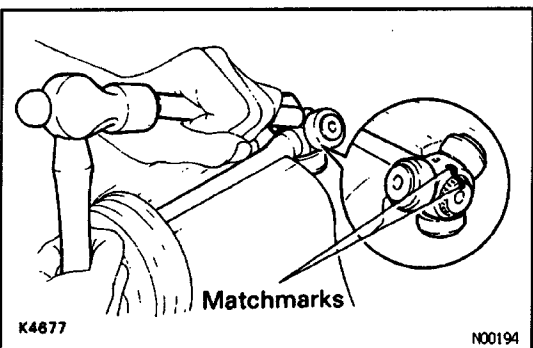

- (b) Place matchmarks on the shaft and tripod.

NOTICE: Do not punch the marks.

- (c) Using a brass bar and a hammer, remove the tripod joint from the drive shaft.

5. REMOVE INBOARD JOINT BOOT

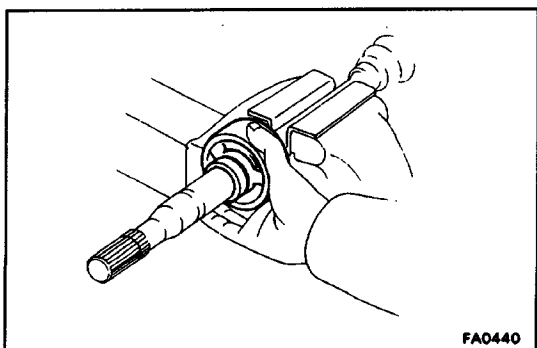

6. RH DRIVE SHAFT:

REMOVE DYNAMIC DAMPER

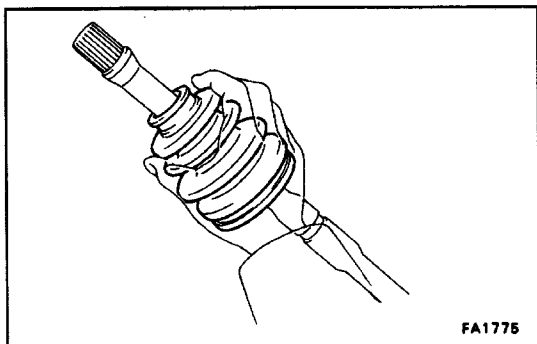

7. REMOVE OUTBOARD JOINT BOOT

- (a) Remove the 2 boot clamps of the outboard joint boot.
- (b) Remove the boot from the outboard joint.

NOTICE: Do not disassemble the outboard joint.

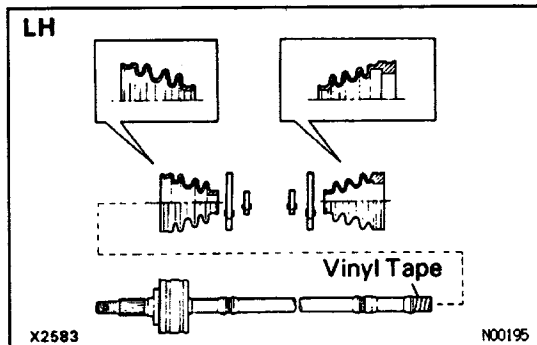

FRONT DRIVE SHAFT ASSEMBLY

8A00V-04

1. TEMPORARILY INSTALL BOOTS, DAMPER (RH DRIVE SHAFT) AND NEW CLAMPS

HINT: Before installing the boot, wrap vinyl tape around the spline of the drive shaft to prevent damaging the boot.

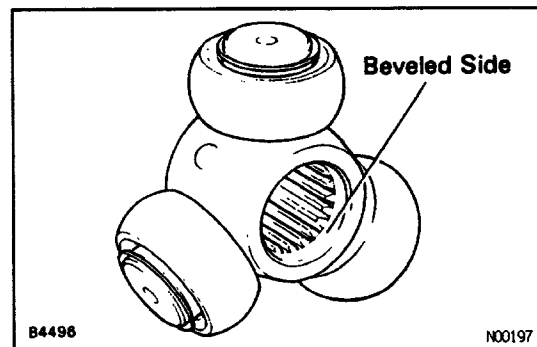
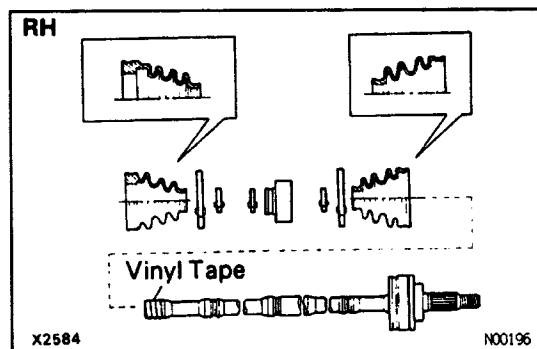

2. INSTALL TRIPOD JOINT

- (a) Place the beveled side of the tripod joint axial spline toward the outboard joint.

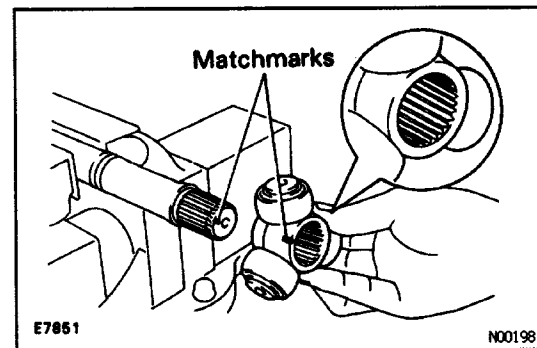

- (b) Align the matchmarks placed before removal.

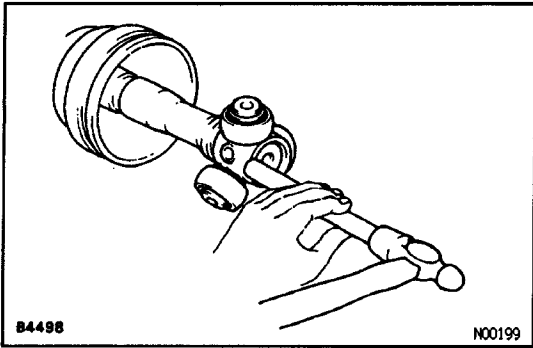

(c) Using a brass bar and a hammer, tap in the tripod joint to the drive shaft.

NOTICE: Do not punch the roller.

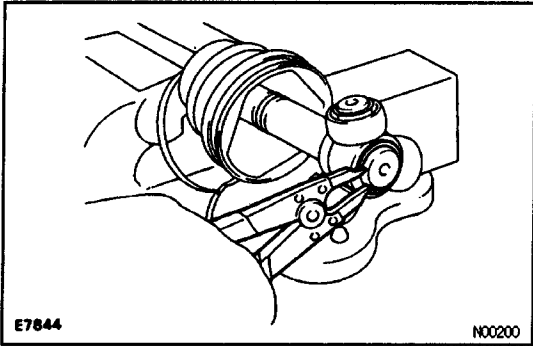

(d) Using a snap ring expander, install a new snap ring.

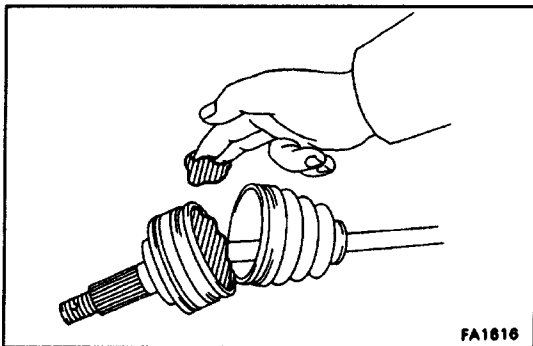

3. INSTALL BOOT TO OUTBOARD JOINT

Before assembling the boot, fill grease into the outboard joint and boot.

HINT: Use the grease supplied in the boot kit.

Grease capacity:

120 - 130 g (0.26 - 0.29 lb. 4.2 - 4.6 oz.)

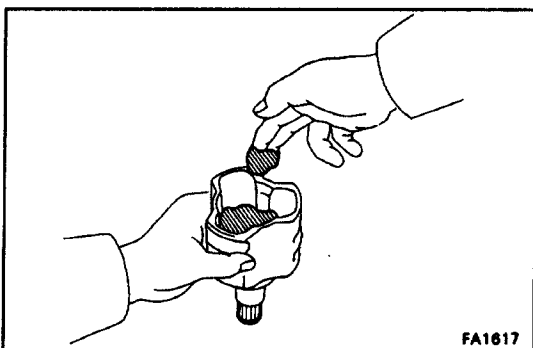

4. INSTALL INBOARD JOINT TO FRONT DRIVE SHAFT

(a) Pack in grease to the inboard tulip and boot.

HINT: Use the grease supplied in the boot kit.

Grease capacity:

140 - 150 g (0.31 - 0.33 lb, 4.9 - 5.3 oz.)

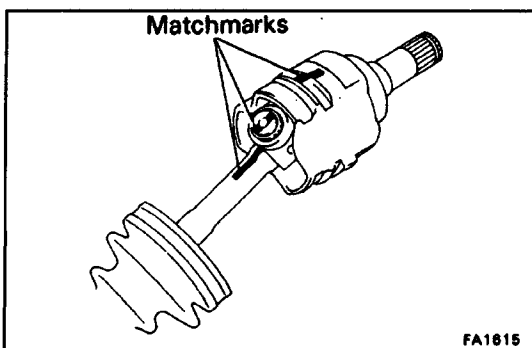

(b) Align the matchmarks placed before disassembly.

(c) Install the inboard joint tulip to the drive shaft.

(d) Temporarily install the boot to the inboard joint tulip.

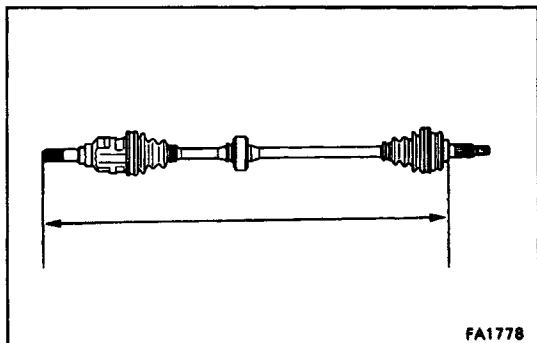

5. ASSEMBLY BOOT CLAMPS AND DYNAMIC DAMPER CLAMP (RH DRIVE SHAFT)

- (a) Be sure the boots are on the shaft groove.
- (b) Set the drive shaft length to the standard.

Standard length:

LH shaft

554.1 ± 5.0 mm (21.815 ± 0.197 in.)

RH shaft

784.4 ± 5.0 mm (30.882 ± 0.197 in.)

- (c) Bend the clamp and lock it, as shown in the illustration.

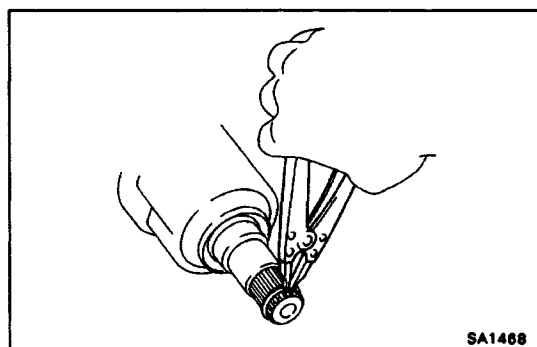
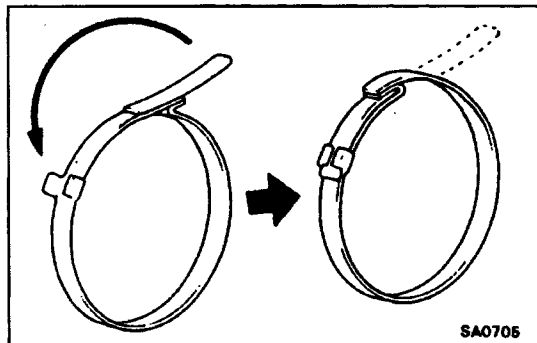

FRONT DRIVE SHAFT INSTALLATION ^{SA04D-03}

1. INSTALL NEW SNAP RING

2. INSTALL DRIVE SHAFT

Using a brass bar and a hammer, install the drive shaft to the transaxle.

3. CHECK INSTALLATION OF FRONT DRIVE SHAFT

- (a) Check that there is 2-3 mm (0.08-0.12 in.) of play in axial direction.
- (b) Check that the drive shaft will not come out by trying to pull it completely out by hand.

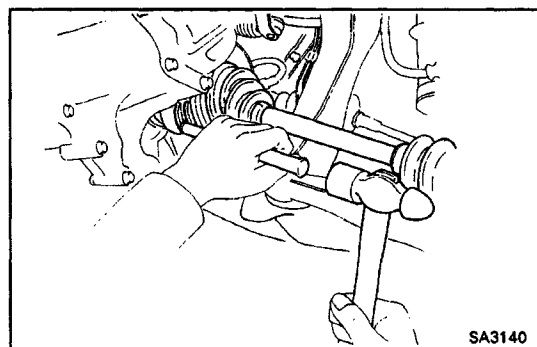

4. CONNECT DRIVE SHAFT TO AXLE HUB

NOTICE: Be careful not to damage the inner oil seal.

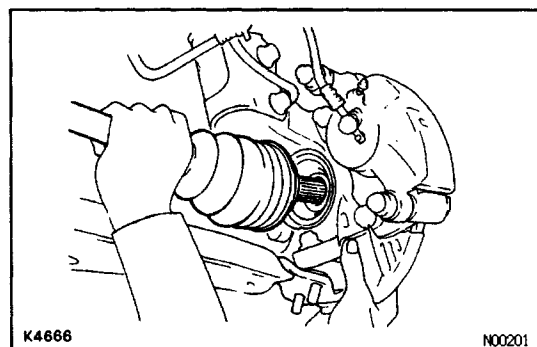

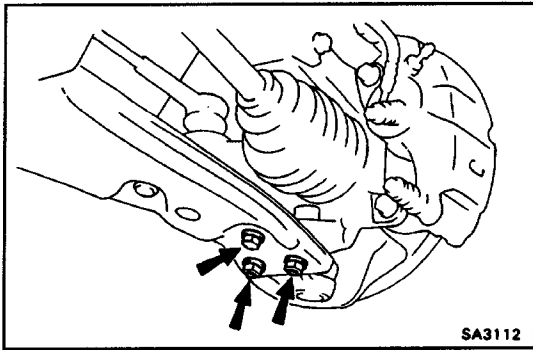
**5. CONNECT LOWER BALL JOINT TO LOWER ARM**

Connect the lower ball joint to the lower arm and tighten the bolt and 2 nuts.

Torque: 80 N-m (820 kgf-cm, 59 ft-lbf)

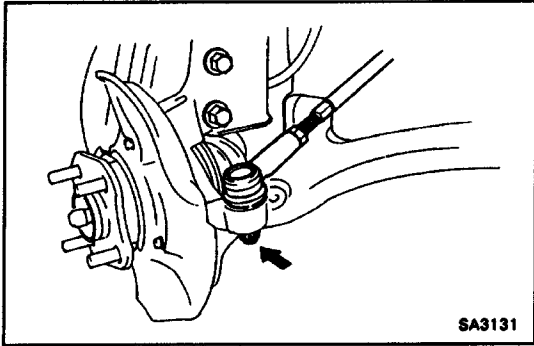
**6. CONNECT TIE ROD END TO STEERING KNUCKLE**

(a) Connect the tie rod end to steering knuckle and tighten the nut.

Torque: 49 N-m (500 kgf-cm, 36 ft-lbf)

(b) Install a new cotter pin.

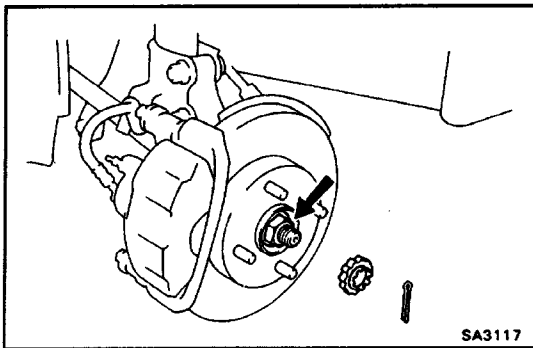
**7. INSTALL DRIVE SHAFT LOCK NUT**

(a) Tighten the lock nut.

Torque: 216 N-m (2,200 kgf-cm, 159 ft-lbf)

(b) Install the lock cap and a new cotter pin.

8. M X:

FILL TRANSAXLE WITH GEAR OIL

AX:

FILL DIFFERENTIAL WITH ATF

9. MX:

INSTALL LH ENGINE UNDER COVER

10. INSTALL FRONT WHEEL AND LOWER VEHICLE

Torque: 103 N-m (1,050 kgf-cm, 76 ft-lbf)

11. INSPECT FRONT WHEEL ALIGNMENT

(See page [SA-5](#))

FRONT SUSPENSION

DESCRIPTION

The front suspension is Mac Pherson strut type suspension with L-shape lower arm.

SA008-01

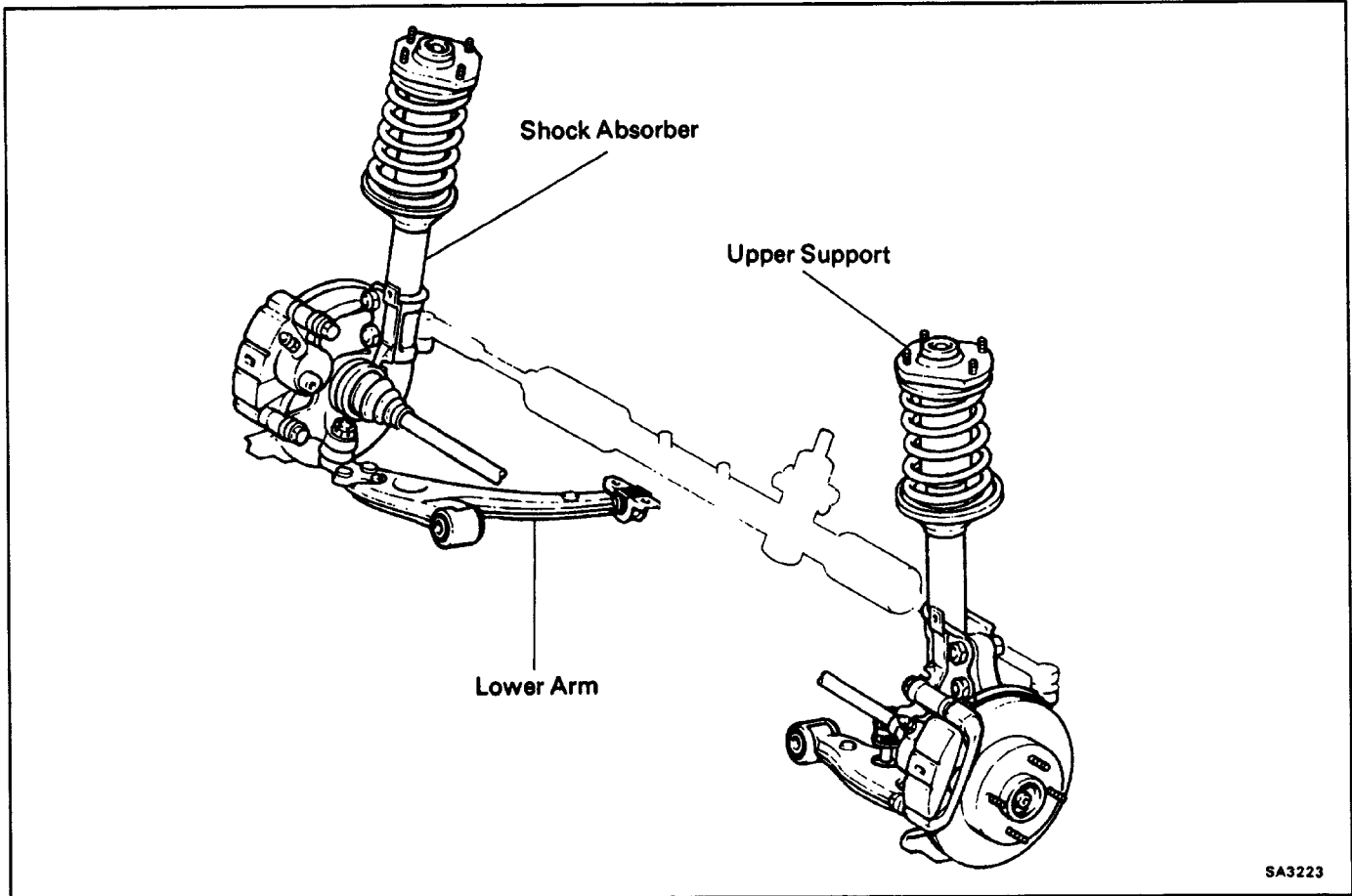



SA3223

PREPARATION

SA009-01

SST (SPECIAL SERVICE TOOLS)

	09727-30020 Coil Spring Compressor	
	09729-22031 Front Spring Upper Seat Holder	
	09628-6201 1 Ball Joint Puller	

EQUIPMENT

SA028-02

Torque wrench	
---------------	--

FRONT SHOCK ABSORBER COMPONENTS

SA00A-09

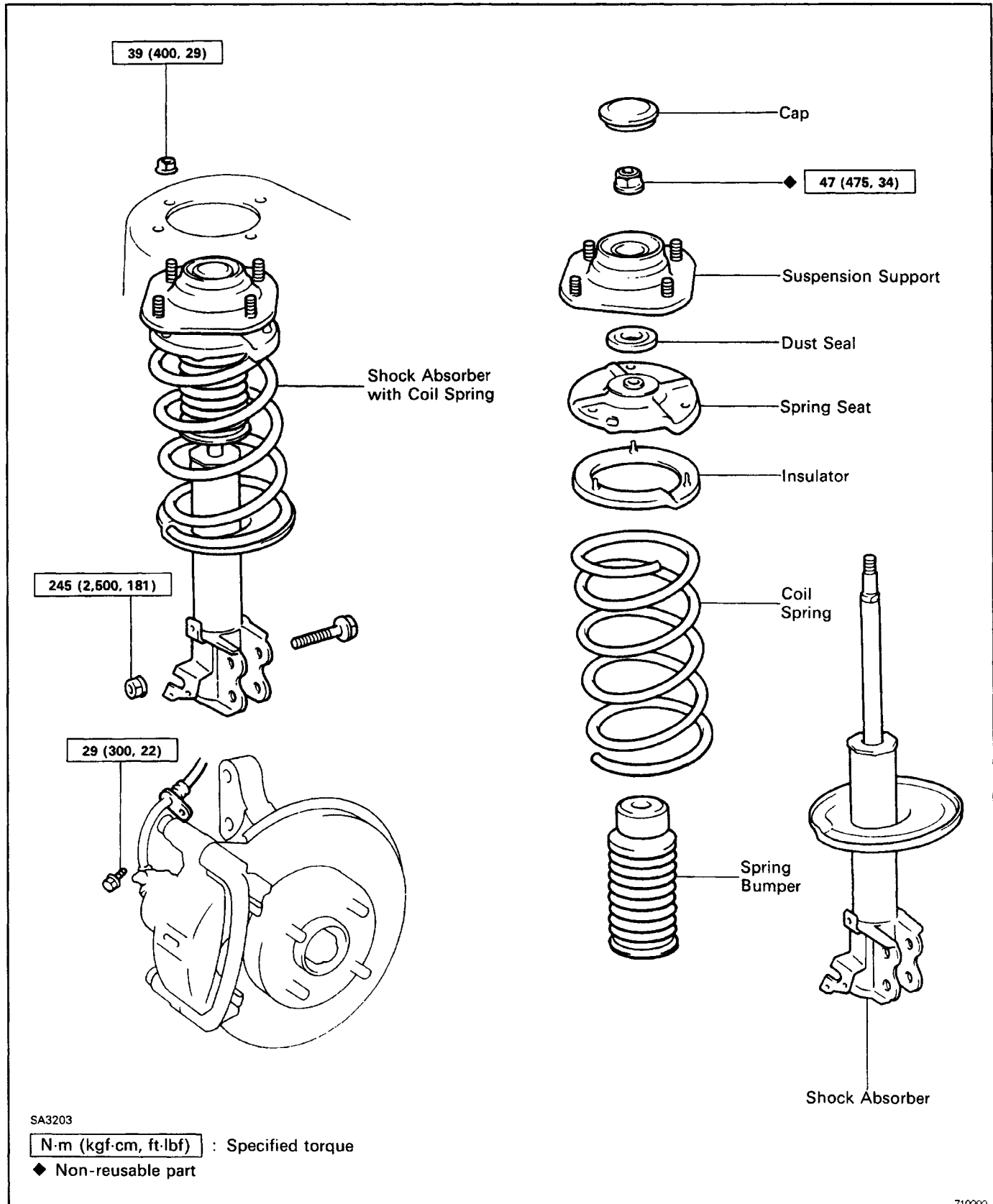

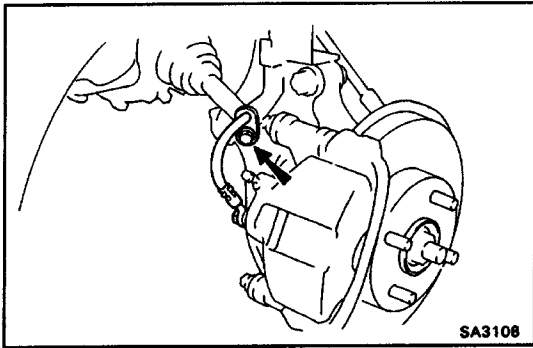

FRONT SHOCK ABSORBER REMOVAL ^{SA00X-03}

1. JACK UP VEHICLE AND REMOVE FRONT WHEEL
2. DISCONNECT BRAKE HOSE FROM SHOCK ABSORBER

Remove the bolt and disconnect the brake hose from the shock absorber.

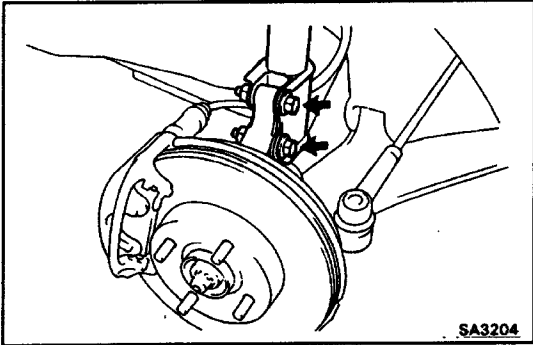

3. DISCONNECT SHOCK ABSORBER FROM STEERING KNUCKLE

Remove the 2 nuts and bolts and disconnect the shock absorber from the steering knuckle.

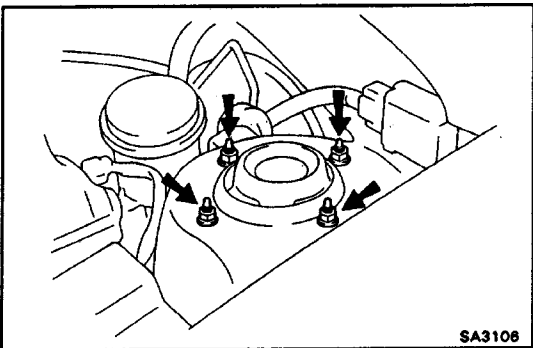

4. REMOVE SHOCK ABSORBER WITH COIL SPRING

- (a) Remove the 4 nuts on upper side of the shock absorber.
- (b) Remove the shock absorber with the coil spring.

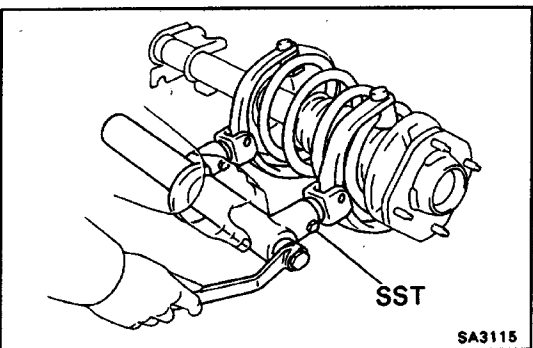

5. REMOVE COIL SPRING

- (a) Using SST, compress the coil spring.
SST 09727-30020

NOTICE: Do not use an impact wrench.
It will damage the SST.

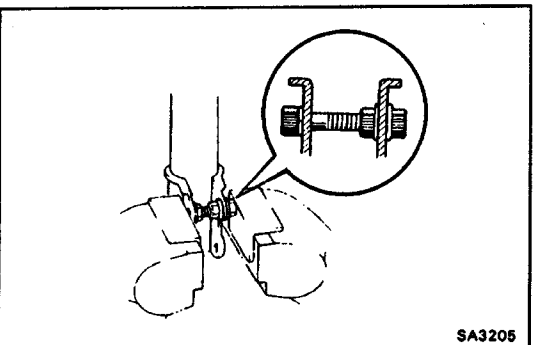

- (b) Install a bolt and 2 nuts to the bracket at the lower portion of the shock absorber and secure it in a vise.

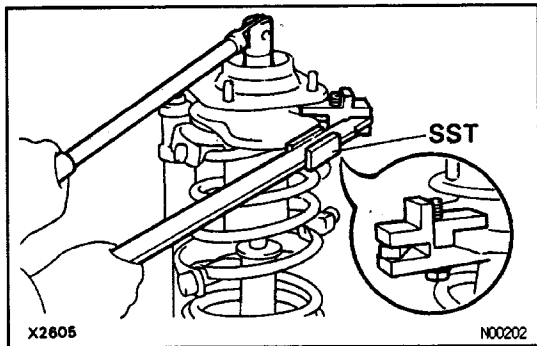

(c) Using SST, to hold the spring seat, remove the nut.
SST 09729-22031

(d) Remove the following parts:

- Suspension support
- Dust seal
- Spring seat
- Insulator
- Coil spring
- Spring bumper

FRONT SHOCK ABSORBER INSPECTION

1. INSPECT SHOCK ABSORBER

Compress and extend the shock absorber rod and check that there is no abnormal resistance or unusual operation sounds.

If there is any abnormality, replace the shock absorber with a new one.

NOTICE: When discarding the shock absorber, use the following procedure.

FRONT SHOCK ABSORBER DISPOSAL

1. FULLY EXTEND SHOCK ABSORBER ROD

2. DRILL HOLE TO REMOVE GAS FROM CYLINDER

Using a drill, make a hole in the cylinder, as shown to remove the gas inside.

CAUTION: The gas coming out is harmless, but be careful of chips which may fly up when drilling.

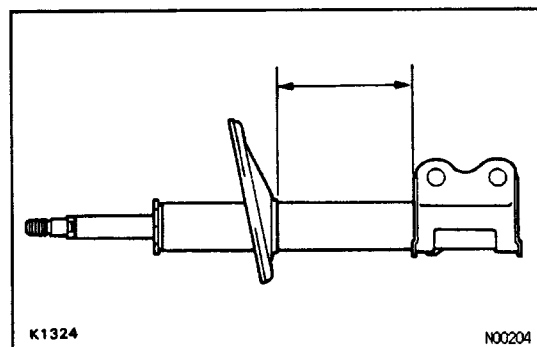
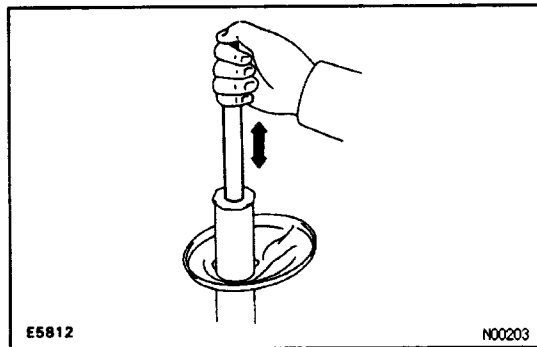

FRONT SHOCK ABSORBER INSTALLATION

1. INSTALL COIL SPRING AND SUSPENSION SUPPORT

(a) Using SST, compress the coil spring.
SST 09727-30020

NOTICE: Do not use an impact wrench.
It will damage the SST.

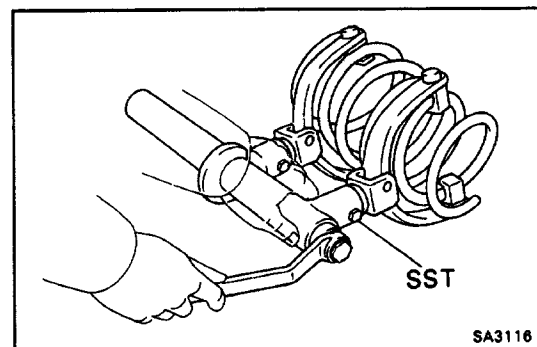

(b) Install the spring bumper to the shock absorber piston rod.

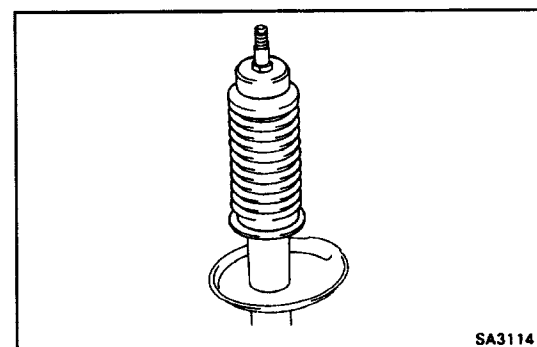

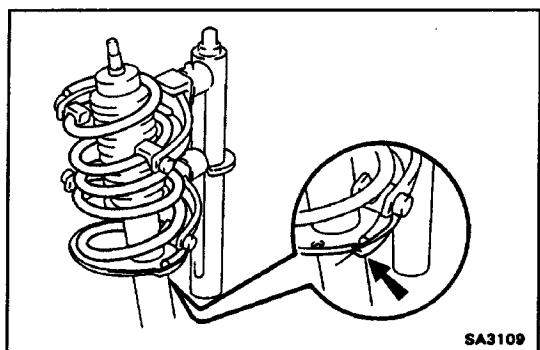

- (c) Install the coil spring to the shock absorber.
HINT: Fit the lower end of the coil spring into the gap of the spring seat of shock absorber.

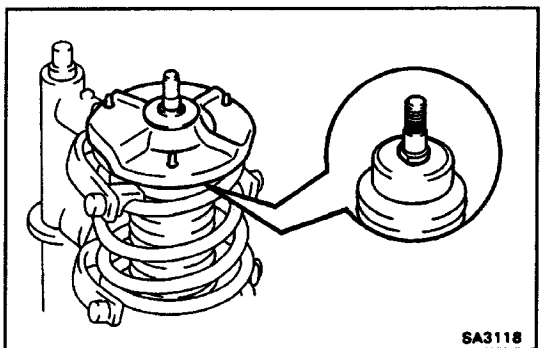

- (d) Install the spring seat with the insulator.

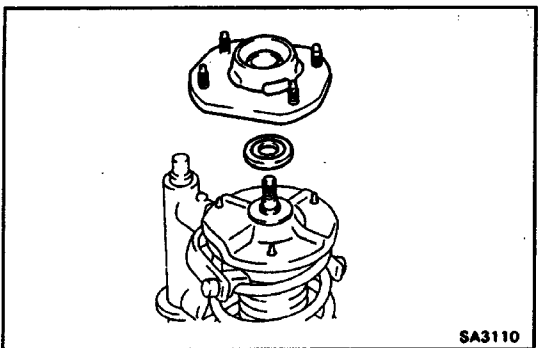

- (e) Install the dust seal and suspension support.

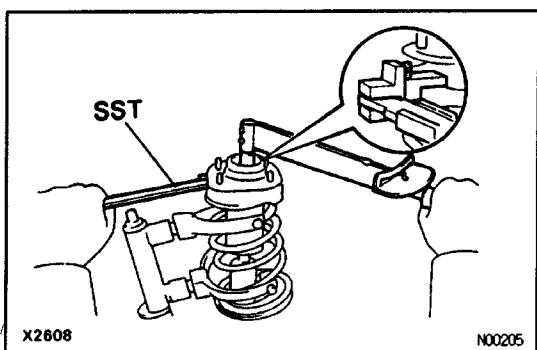

- (f) Using SST, to hold the spring seat, install a new nut.
SST 09729-22031
Torque: 47 N-m (475 kgf-cm, 34 ft-lbf)
(g) Remove the SST.

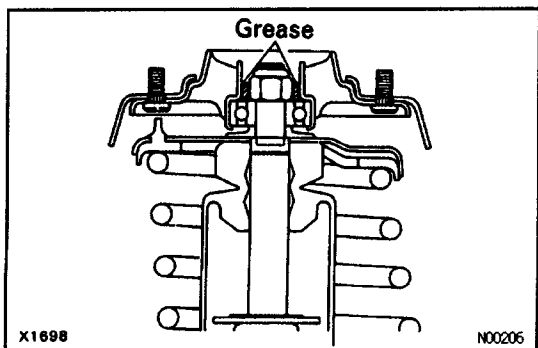

- (h) Pack MP grease into the suspension support.
(i) Install the cap.

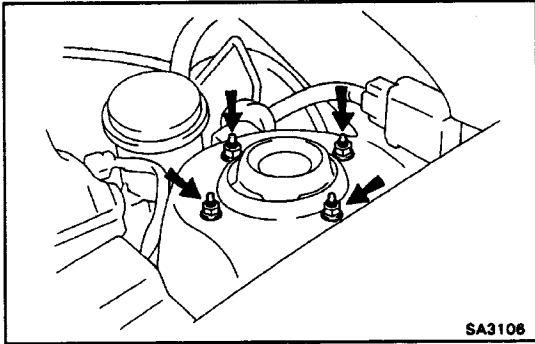

2. INSTALL SHOCK ABSORBER WITH COIL SPRING

Place the shock absorber and install the 4 nuts.

Torque: 39 N-m (400 kgf-cm, 29 ft-lbf)

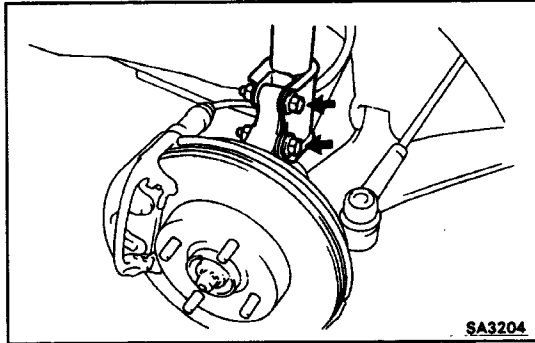

3. CONNECT SHOCK ABSORBER TO STEERING KNUCKLE

- (a) Coat the threads of the bolt with engine oil.
- (b) Install the 2 bolts and nuts.
- (c) Torque the nuts.

Torque: 245 N-m (2,500 kgf-cm, 181 ft-lbf)

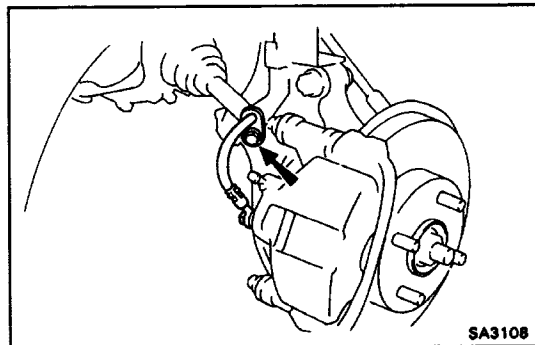

4. CONNECT BRAKE HOSE TO SHOCK ABSORBER

Connect the brake hose to the shock absorber and install the bolt.

Torque: 29 N-m (300 kgf-cm, 22 ft-lbf)

5. INSTALL FRONT WHEEL AND LOWER VEHICLE

Torque: 103 N-m (1,050 kgf-cm, 76 ft-lbf)

6. INSPECT FRONT WHEEL ALIGNMENT

(See page [SA-5](#))

LOWER SUSPENSION ARM COMPONENTS

SA008-08

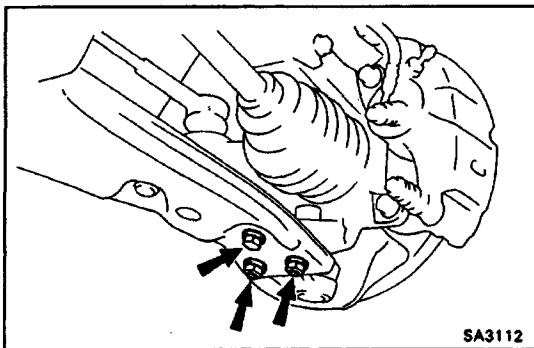
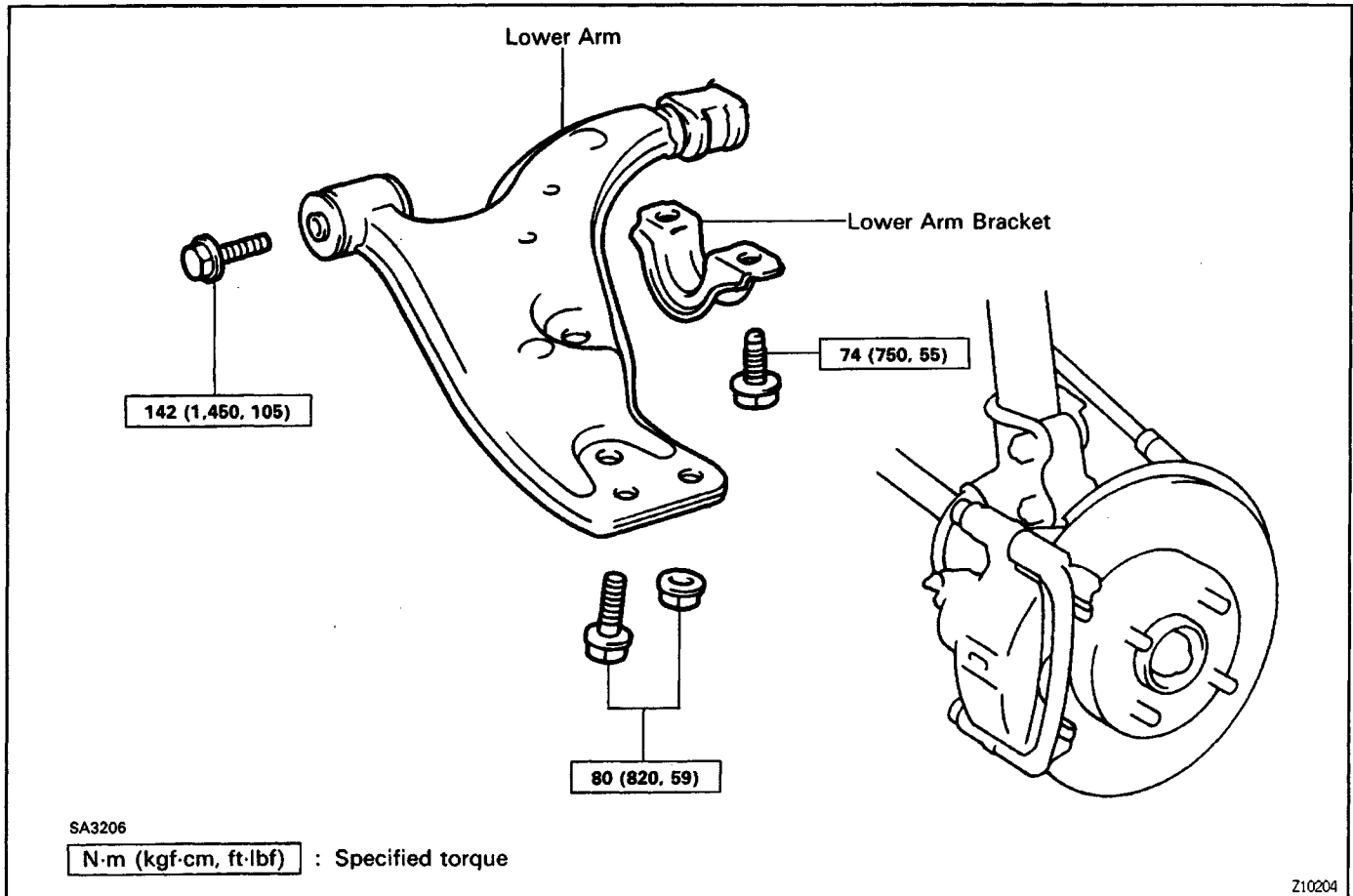

LOWER ARM REMOVAL

SA011-02

1. JACK UP VEHICLE AND REMOVE FRONT WHEEL
2. DISCONNECT LOWER ARM FROM LOWER BALL JOINT

Remove the bolt and 2 nuts.

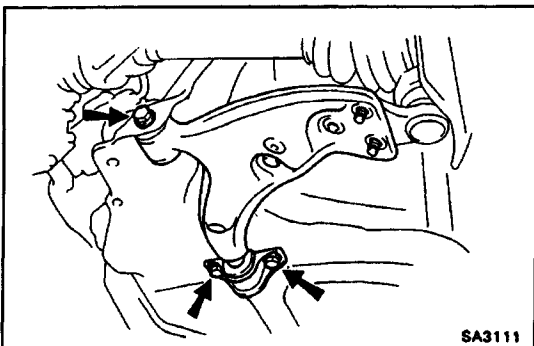

3. REMOVE LOWER ARM

Remove the 3 bolts and the lower arm.

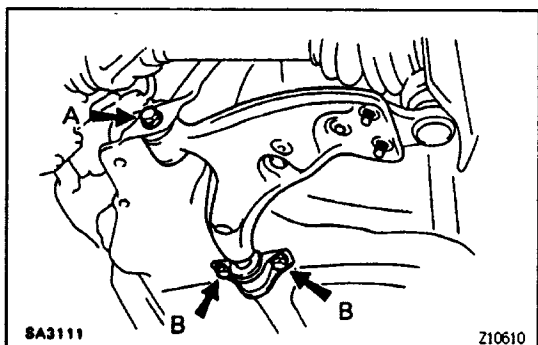

LOWER ARM INSTALLATION

1. TEMPORARILY INSTALL LOWER ARM

- Place the lower arm with the lower arm bracket.
- Temporarily install the 3 bolts.

Torque:

A: 142 N-m (1,450 kgf-cm, 105 ft-lbf)

B: 74 N-m (750 kgf-cm, 55 ft-lbf)

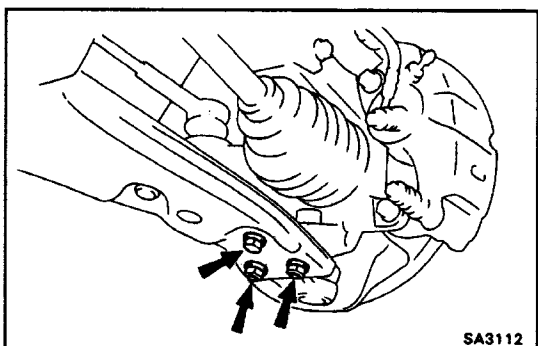

2. CONNECT LOWER ARM TO LOWER BALL JOINT

Connect the lower arm to the lower ball joint and install the bolt and 2 nuts.

Torque: 80 N-m (820 kgf-cm, 59 ft-lbf)

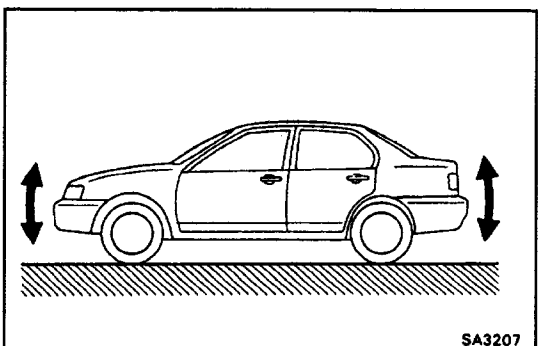

3. STABILIZE SUSPENSION

- Install the front wheel and lower vehicle.
- Torque:** 103 N-m (1,050 kgf-cm, 76 ft-lbf)
- Bounce the vehicle up and down several times to stabilize the suspension.

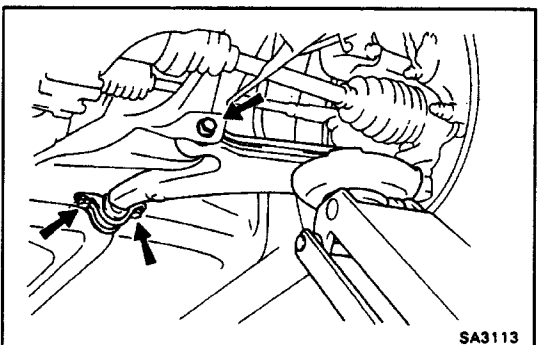

4. TORQUE BOLTS

- Jack up the vehicle and support the body with stands.
- Support the lower with a jack.
- Torque the 3 bolts.

Front side:

Torque: 142 N-m (1,450 kgf-cm, 105 ft-lbf)

Rear side:

Torque: 74 N-m (750 kgf-cm, 55 ft-lbf)

5. INSPECT FRONT WHEEL ALIGNMENT

(See page [SA-5](#))

LOWER BALL JOINT COMPONENTS

SA00C-04

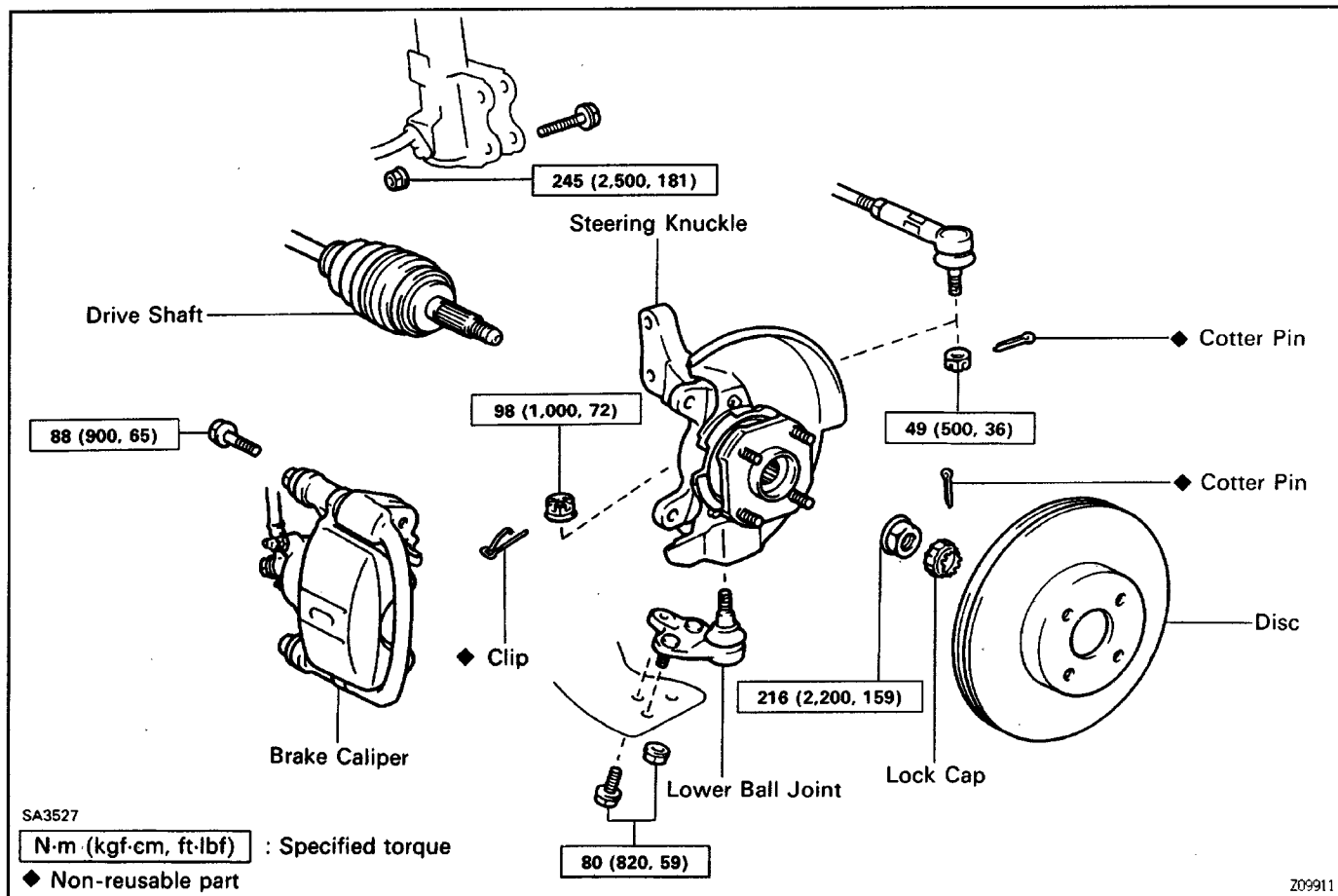

SA013-01

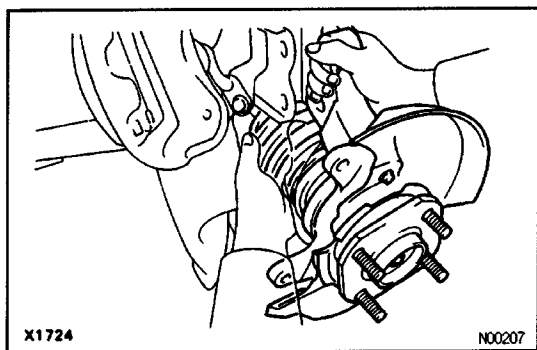

LOWER BALL JOINT REMOVAL

1. REMOVE STEERING KNUCKLE WITH AXLE HUB
(See page SA-11)

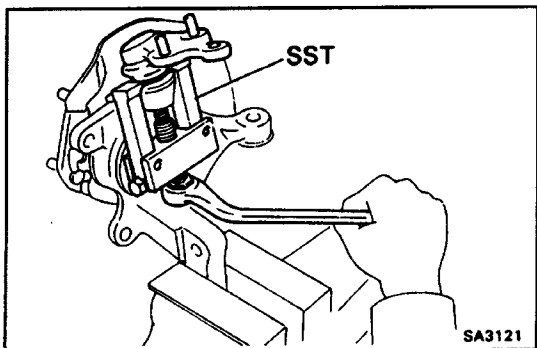

2. REMOVE LOWER BALL JOINT

- (a) Remove the clip and nut.
- (b) Using SST, remove the lower ball joint.
SST 09628-62011

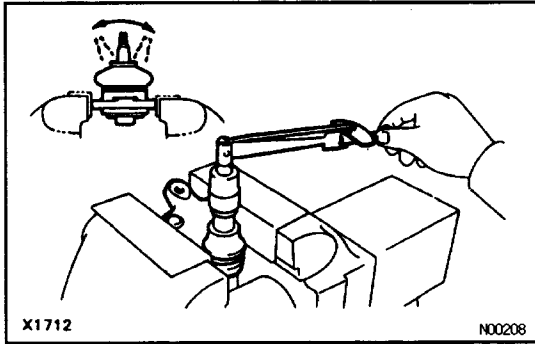

LOWER BALL JOINT INSPECTION

SA014-02

INSPECT BALL JOINT FOR ROTATION CONDITION

- (a) As shown, flip the ball joint stud back and forth 5 times before installing the nut.
- (b) Using a torque gauge, turn the nut continuously 1 turn per 2-4 seconds and take the torque reading on the 5th turn.

Torque (Turning):

1.0 - 2.9 N-m (10 - 30 kgf-cm, 8.7 - 26 in.-lbf)

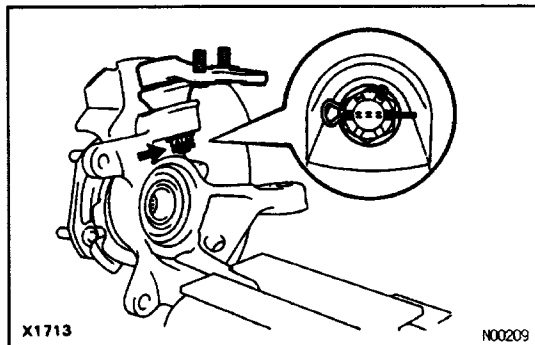

LOWER BALL JOINT INSTALLATION

SA015-01

1. INSTALL LOWER BALL JOINT TO STEERING KNUCKLE

- (a) Install the lower ball joint and tighten the nut.

Torque: 98 N-m (1,000 kgf-cm, 72 ft-lbf)

- (b) Install a new clip.

2. INSTALL STEERING KNUCKLE WITH AXLE HUB

(See page [SA-16](#))

REAR AXLE





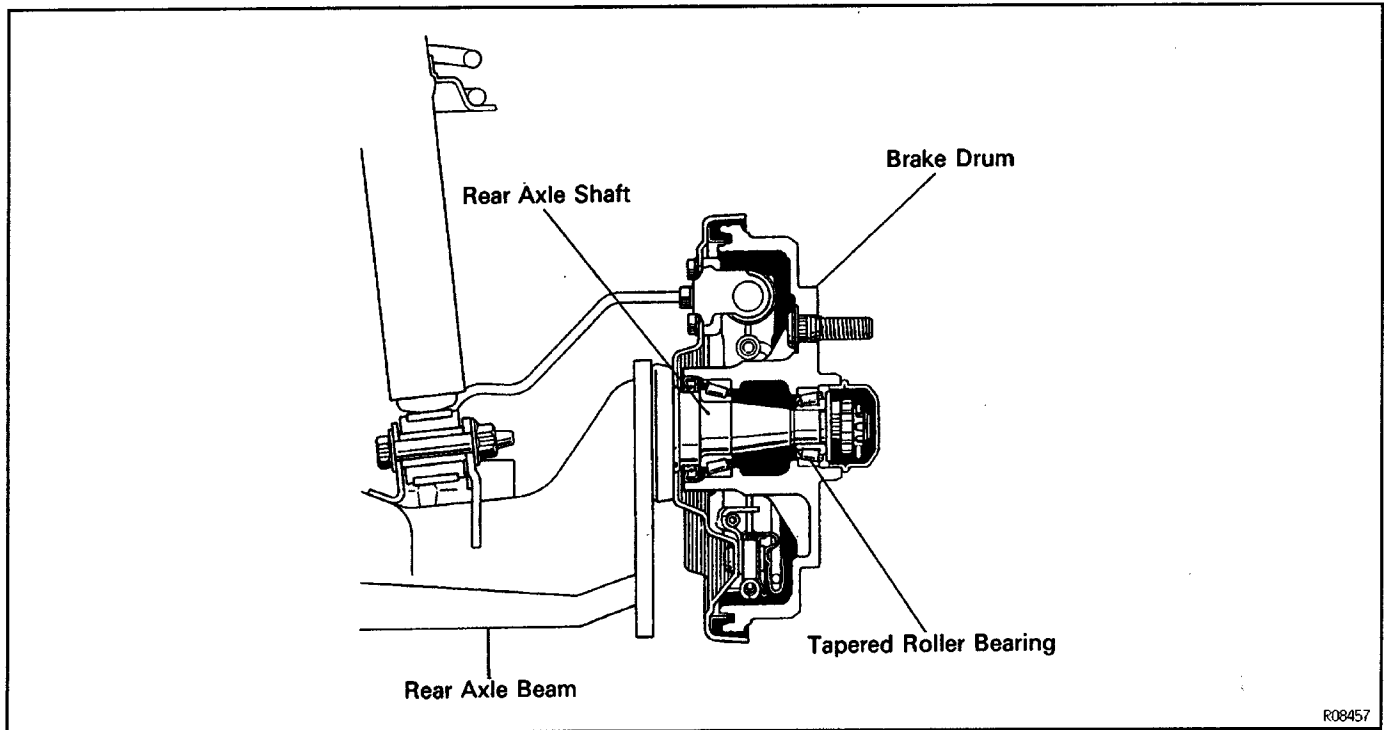

DESCRIPTION

Tapered roller bearings are used for the wheel bearings. The brake drum is integrated with the axle hub to reduce the overall weight.



PREPARATION**SST (SPECIAL SERVICE TOOLS)**

SA016-03

	09308-00010 Oil Seal Puller	
	09550-10012 Replacer Set "B"	
	(09552-10010) No. 2 Replacer Handle	
	(09553 -10010) Differential Side Bearing Replacer	
	09608-30012 Front Hub & Drive Pinion Bearing Tool Set	
	(09608-04020) Handle	
	(09608-04060) Front Hub Outer Bearing Cup Replacer	

SA07V-03

EQUIPMENT

Torque wrench	
Spring tension gauge	

REAR AXLE HUB COMPONENTS

SA00E-01

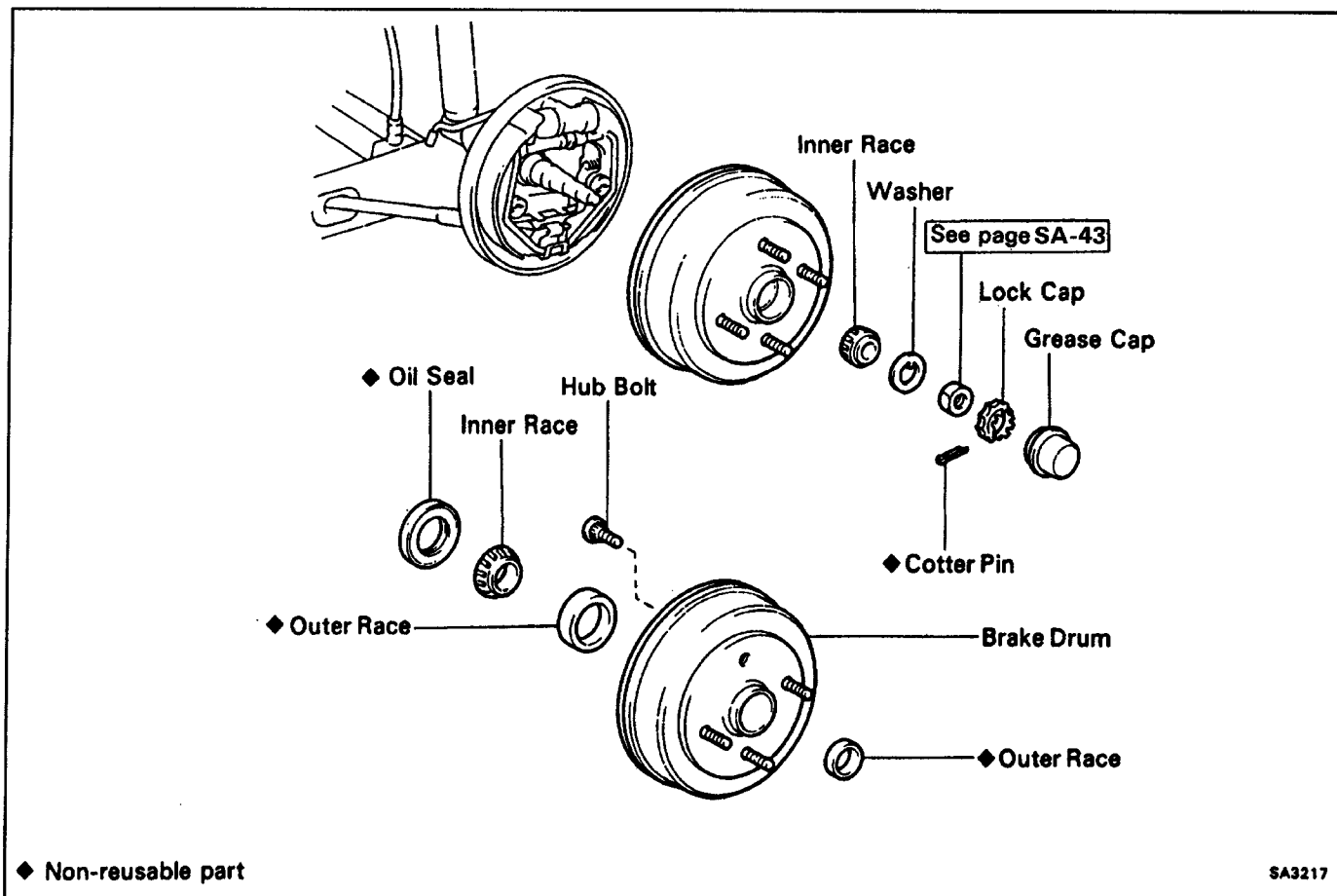

SA017-00

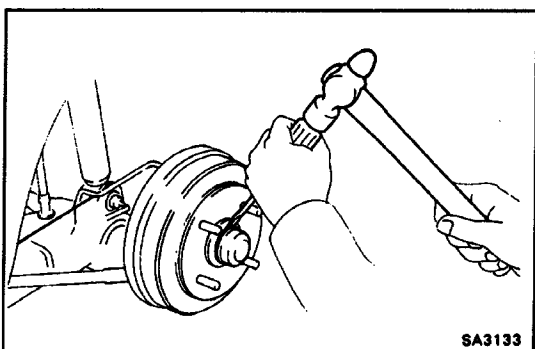

REAR AXLE HUB REMOVAL

1. JACK UP VEHICLE AND REMOVE REAR WHEEL
2. REMOVE GREASE CAP

Using a screwdriver and a hammer, remove the grease cap.

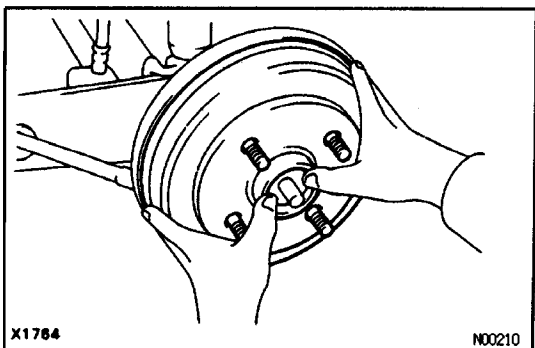

3. REMOVE AXLE HUB

- (a) Remove the cotter pin and lock cap.
- (b) Remove the nut.
- (c) Remove the axle hub with bearings.

NOTICE: Be careful not to drop the outer bearing.

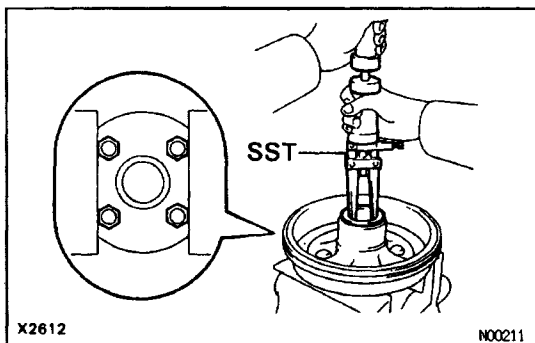

BEARING REPLACEMENT

1. REMOVE OIL SEAL AND INNER BEARING

- (a) Using SST, remove the oil seal.
SST 09308-00010
- (b) Remove the inner bearing.

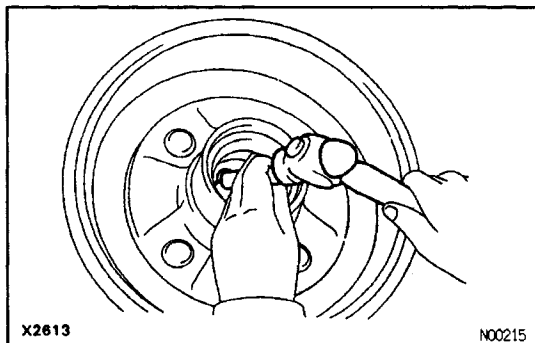

2. REMOVE OUTER RACE

Using a brass bar and hammer, drive out the outer race.

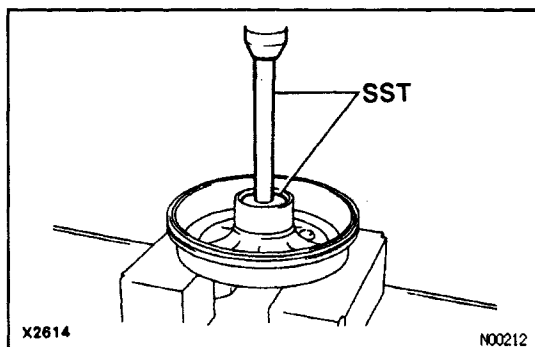

3. INSTALL OUTER RACE

Using SST and a press, install new bearing outer races.

Inside

SST 09608 - 30012 (09608 - 04020, 09608 - 04060)

Outside

SST 09550-10012 (09552-10010, 09553-10010)

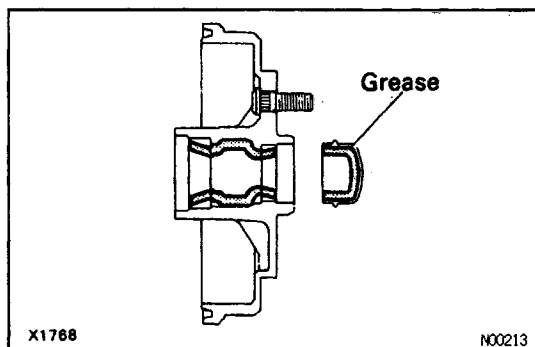

4. INSTALL NEW OIL SEAL

- (a) Pack the bearings with MP grease.
- (b) Coat the inside of the axle hub and grease cap with MP grease.

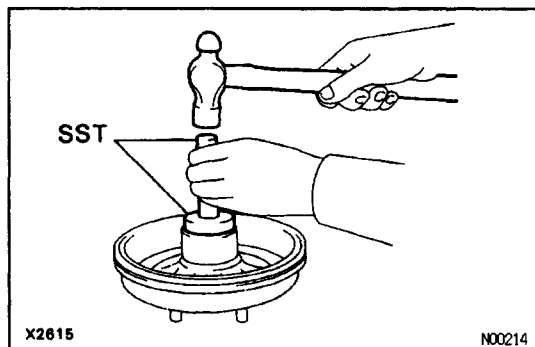

- (c) Install the inner bearing.
- (d) Using SST and a hammer, install a new oil seal.
SST 09550-10012 (09552-10010, 09557-10010)
- (e) Coat the lip of the oil seal with MP grease.

REAR AXLE HUB INSTALLATION

1. INSTALL REAR AXLE HUB

- (a) Install the axle hub.
- (b) Install the outer bearing and washer.
- (c) Temporarily install the nut.

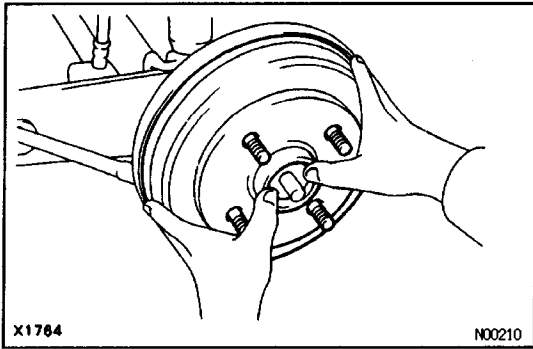

2. ADJUST BEARING PRELOAD

- (a) Torque the nut.
Torque: 29 N-m (300 kgf-cm, 22 ft-lbf)
- (b) Snug down the bearings by turning the axle hub several times.

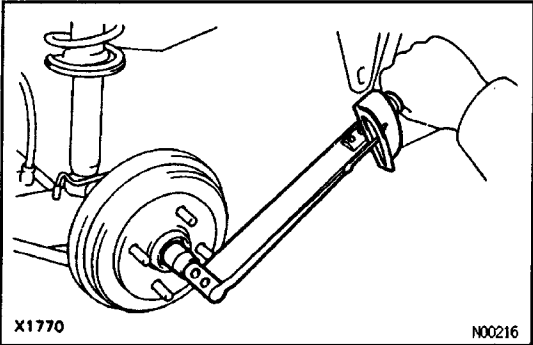

- (c) Loosen the nut until it can be turned by hand.

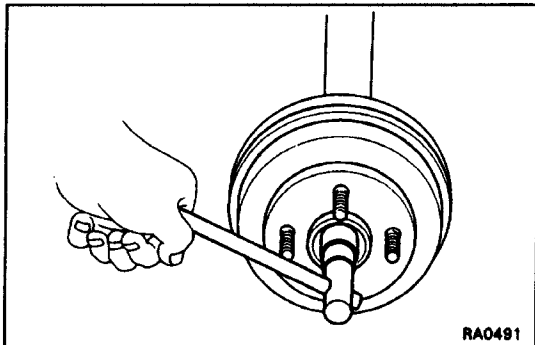

- (d) Measure the rotation frictional force of the oil seal.

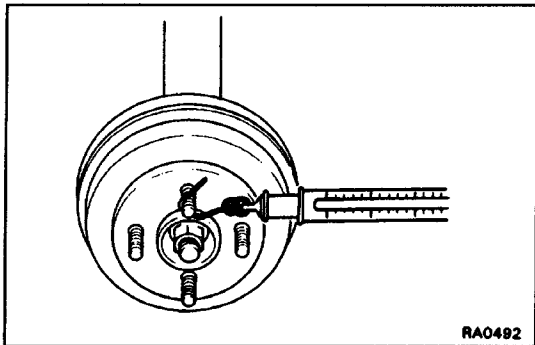

- (e) Tighten the nut until the preload is within standard.

Preload (while turning):

Add frictional force plus

0-1 1.8 N (0 - 12 kgf, 0 - 2.6 lbf)

- (f) Install the lock cap and a new cotter pin.

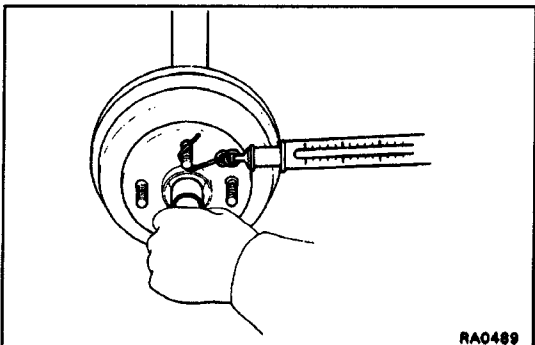

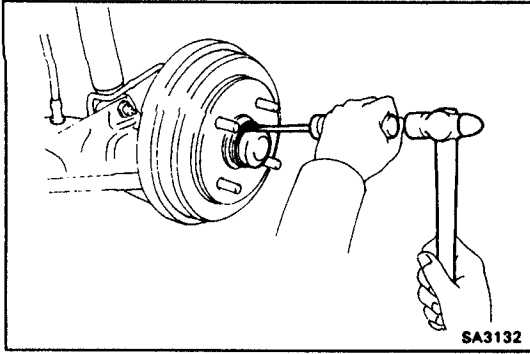

3. INSTALL GREASE CAP

Using a screwdriver and hammer, install the grease cap.

4. INSTALL REAR WHEEL AND LOWER VEHICLE

Torque: 103 N-m (1,050 kgf-cm, 76 ft-lbf)

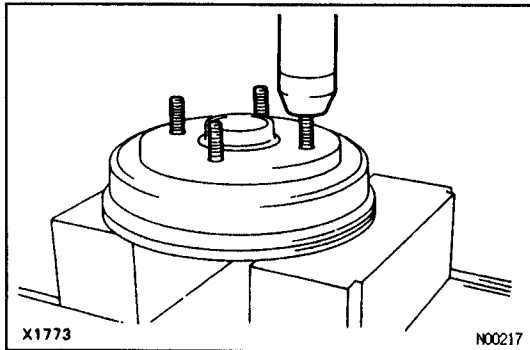

HUB BOLT REPLACEMENT

SA01A-02

1. REMOVE AXLE HUB

(See page [SA-41](#))

2. REMOVE HUB BOLT

Using a press, remove the hub bolt.

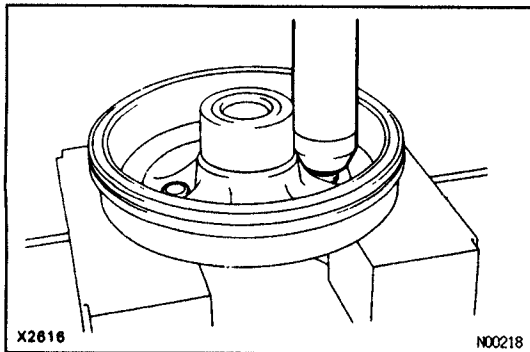

3. INSTALL HUB BOLT

Using a press, install a new hub bolt to the axle hub.

4. INSTALL AXLE HUB

(See page [SA-43](#))

REAR SUSPENSION

DESCRIPTION

A trailing twist beam with built in stabilizer is used for rear suspension.



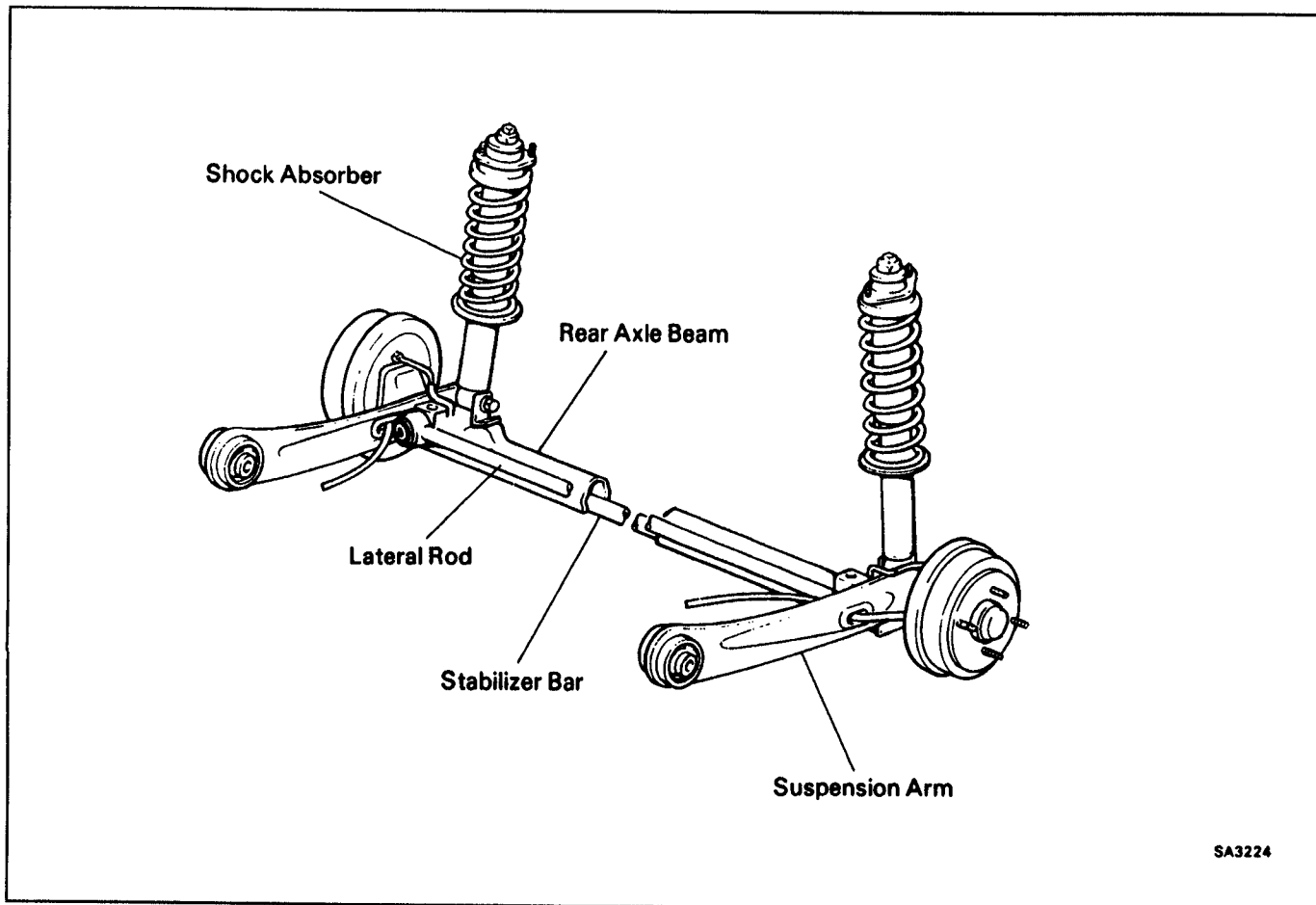

SA00F-01

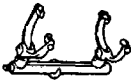
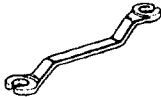
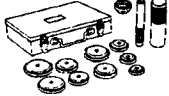

PREPARATION

SA018-01

SST (SPECIAL SERVICE TOOLS)

	09727-30020 Coil Spring Compressor	
	09751-36011 Brake Tube Union Nut 10 x 12 mm Wrench	
   	09608-35014 Axle Hub & Drive Pinion Bearing Tool Set (09608-06020) Handle (09608-06030) Front Hub Inner Bearing Cone Replacer Attachment (09608-06090) Front Hub Outer & Steering Worm Bearing Replacer	

SA014-01

EQUIPMENT

Torque wrench	
---------------	--

REAR SHOCK ABSORBER COMPONENTS

SA006-04

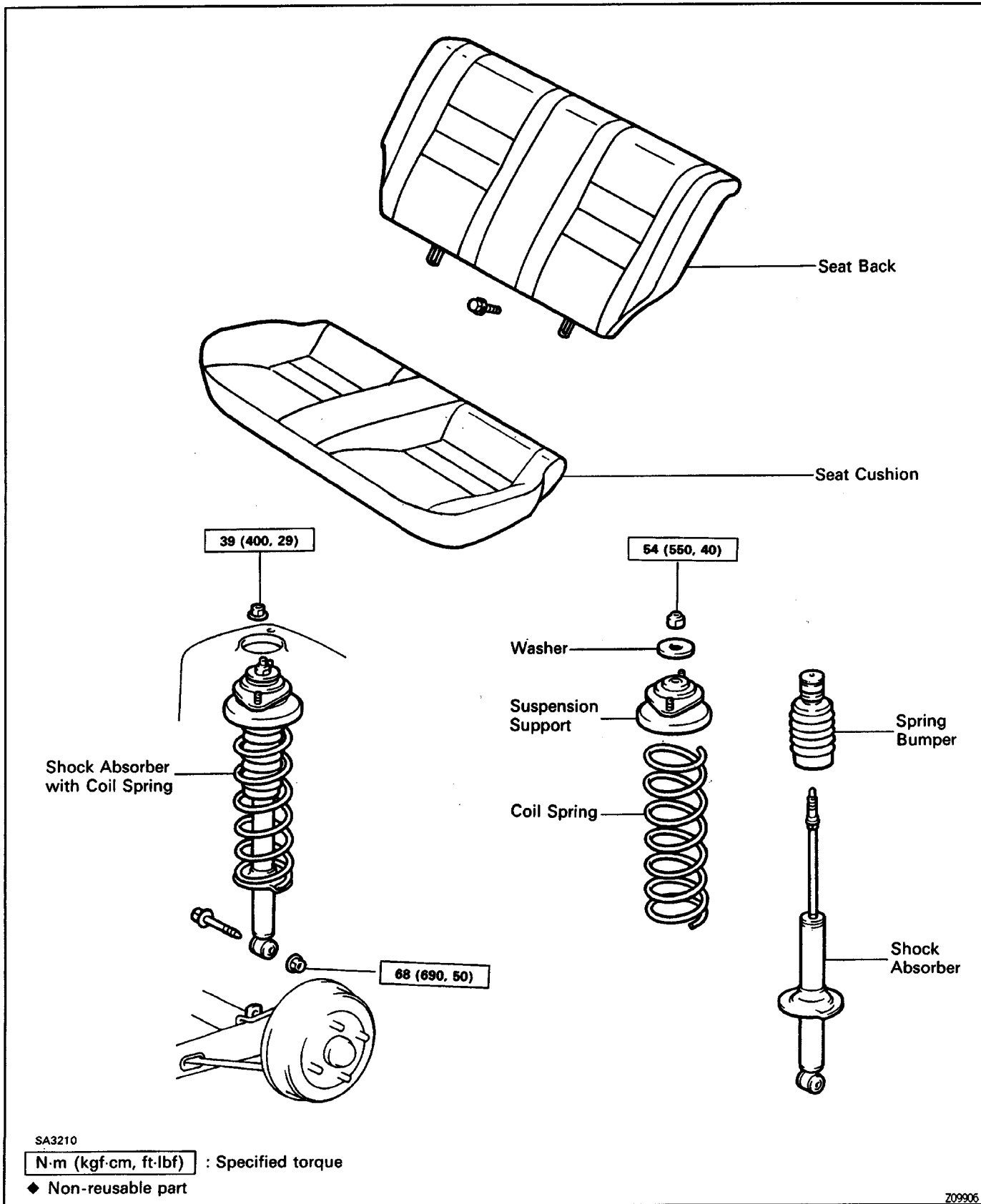

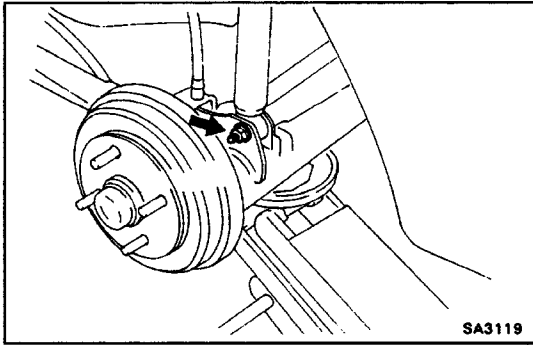

SA3119

REAR SHOCK ABSORBER REMOVAL

1. REMOVE REAR SEAT CUSHION AND SEAT BACK
2. JACK UP VEHICLE AND REMOVE REAR WHEEL
3. REMOVE SHOCK ABSORBER WITH COIL SPRING

- (a) Support the axle beam with a jack.
- (b) Remove the nut and bolt on lower side of the shock absorber.

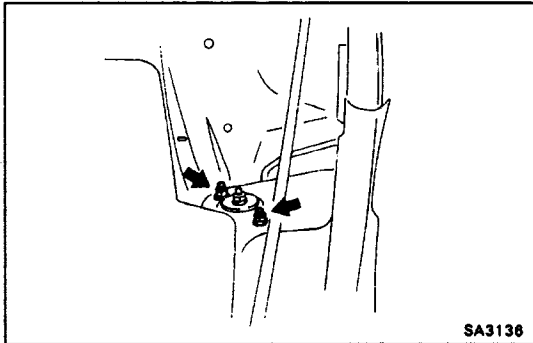

SA3136

- (c) Remove the 2 nuts on upper side of the shock absorber.
- (d) Remove the shock absorber with coil spring.

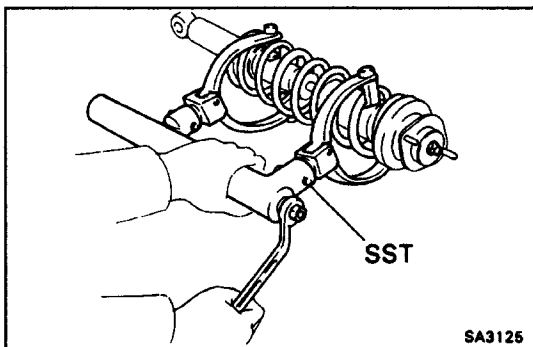

SA3125

4. REMOVE COIL SPRING

- (a) Using SST, compress the coil spring.
SST 09727-30020

**NOTICE: Do not use an impact wrench.
It will damage the SST.**

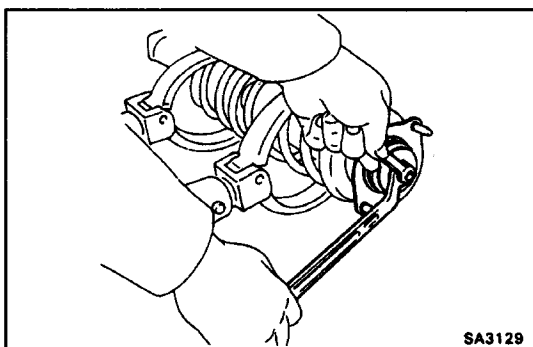

SA3129

- (b) Remove the nut.
- (c) Remove the following parts:
 - Washer
 - Suspension support
 - Spring bumper
 - Coil spring

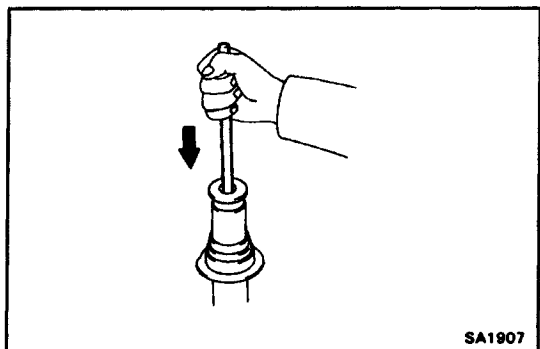

REAR SHOCK ABSORBER INSPECTION

INSPECT SHOCK ABSORBER

Compress and extend the shock absorber rod and check that there is no abnormal resistance or unusual operation sounds.

If there is any abnormality, replace the shock absorber with a new one.

NOTICE: When discarding the shock absorber, use the following procedure.

REAR SHOCK ABSORBER DISPOSAL

1. FULLY EXTEND SHOCK ABSORBER ROD
2. DRILL HOLE TO REMOVE GAS FROM CYLINDER

Using a drill, make a hole in the cylinder, as shown to remove the gas inside.

CAUTION: The gas coming out is harmless, but be careful of chips which may fly up when drilling.

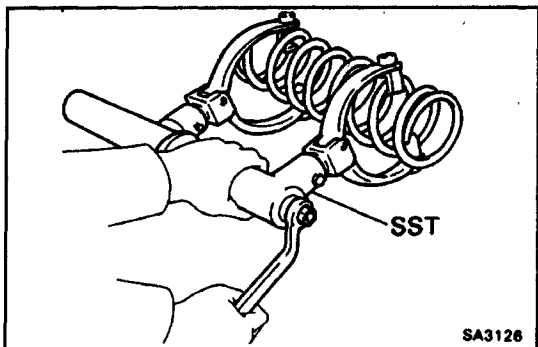
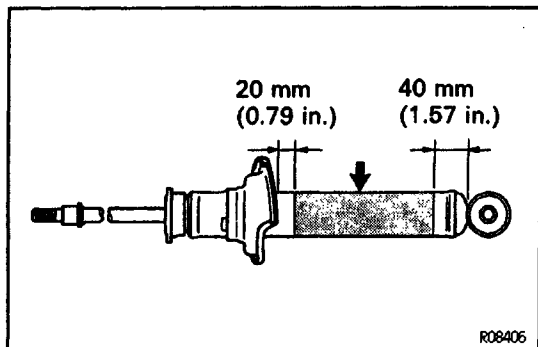

REAR SHOCK ABSORBER INSTALLATION

1. INSTALL COIL SPRING

(a) Using SST, compress the coil spring.

SST 09727-30020

NOTICE: Do not use an impact wrench. It will damage the SST.

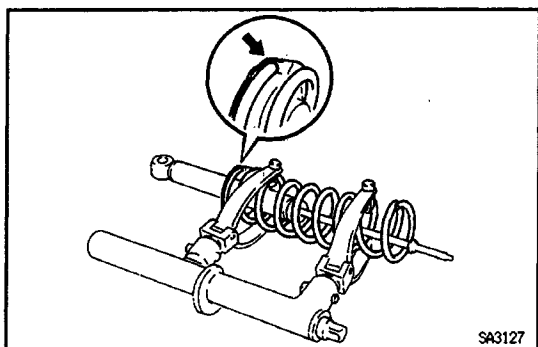

(b) Install the coil spring to the shock absorber.

HINT: Fit the lower end of the coil spring into the gap of the spring seat of shock absorber.

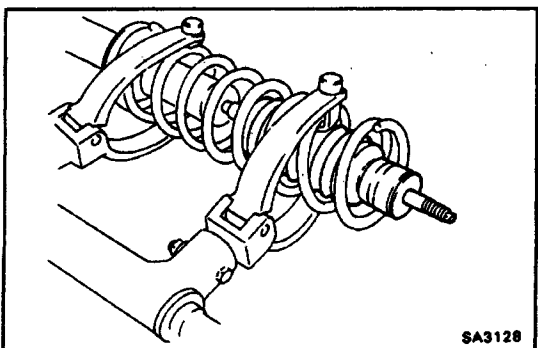

(c) Install the spring bumper to the shock absorber piston rod.

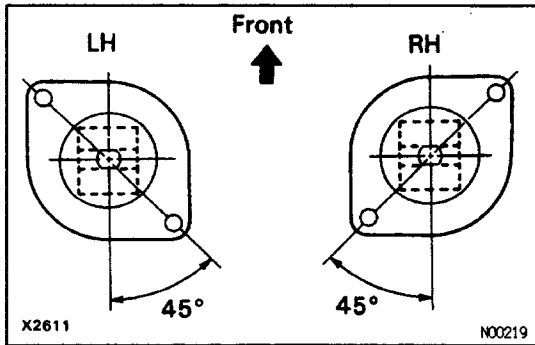

- (d) Align the suspension support with the shock absorber lower bracket, as shown and install it.
- (e) Install the washer.

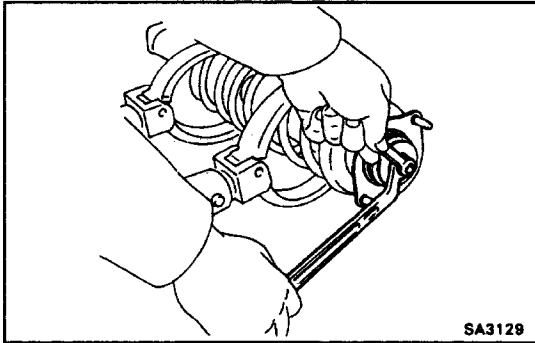

- (f) Install a new nut and torque it.
Torque: 54 N-m (550 kgf-cm, 40 ft-lbf)
- (g) Remove the SST.

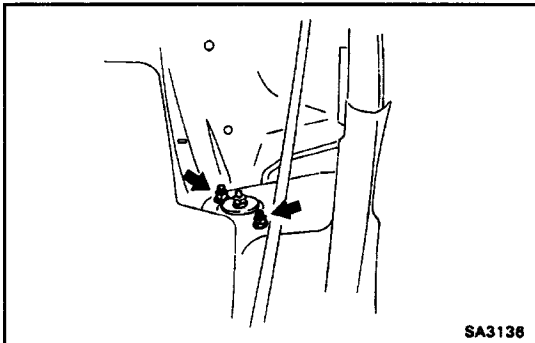

2. INSTALL SHOCK ABSORBER WITH COIL SPRING

Place the shock absorber and install the 2 nuts.

Torque: 39 N-m (400 kgf-cm, 29 ft-lbf)

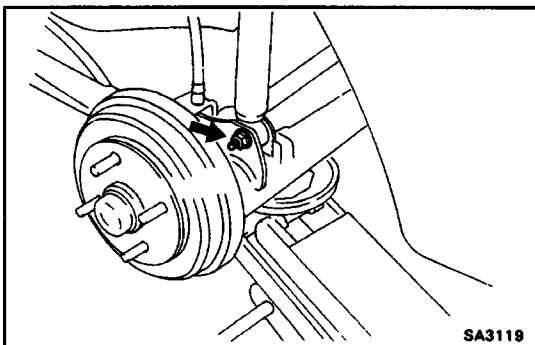

3. CONNECT SHOCK ABSORBER TO AXLE BEAM

Temporarily install the bolt and nut.

4. STABILIZE SUSPENSION

- (a) Install the rear wheel and lower vehicle.
Torque: 103 N-m (1,050 kgf-cm, 76 ft-lbf)
- (b) Bounce the vehicle up and down several times to stabilize the suspension.

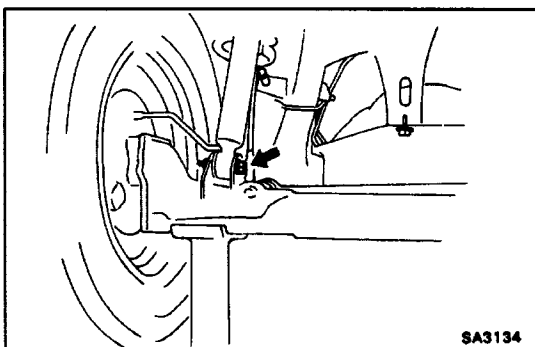

5. TORQUE NUT

- (a) Jack up the vehicle and support the axle beam with stands.
- (b) Torque the nut on lower side of the shock absorber.
Torque: 68 N-m (690 kgf-cm, 50 ft-lbf)

6. LOWER VEHICLE

AXLE BEAM COMPONENTS

8A00H-01

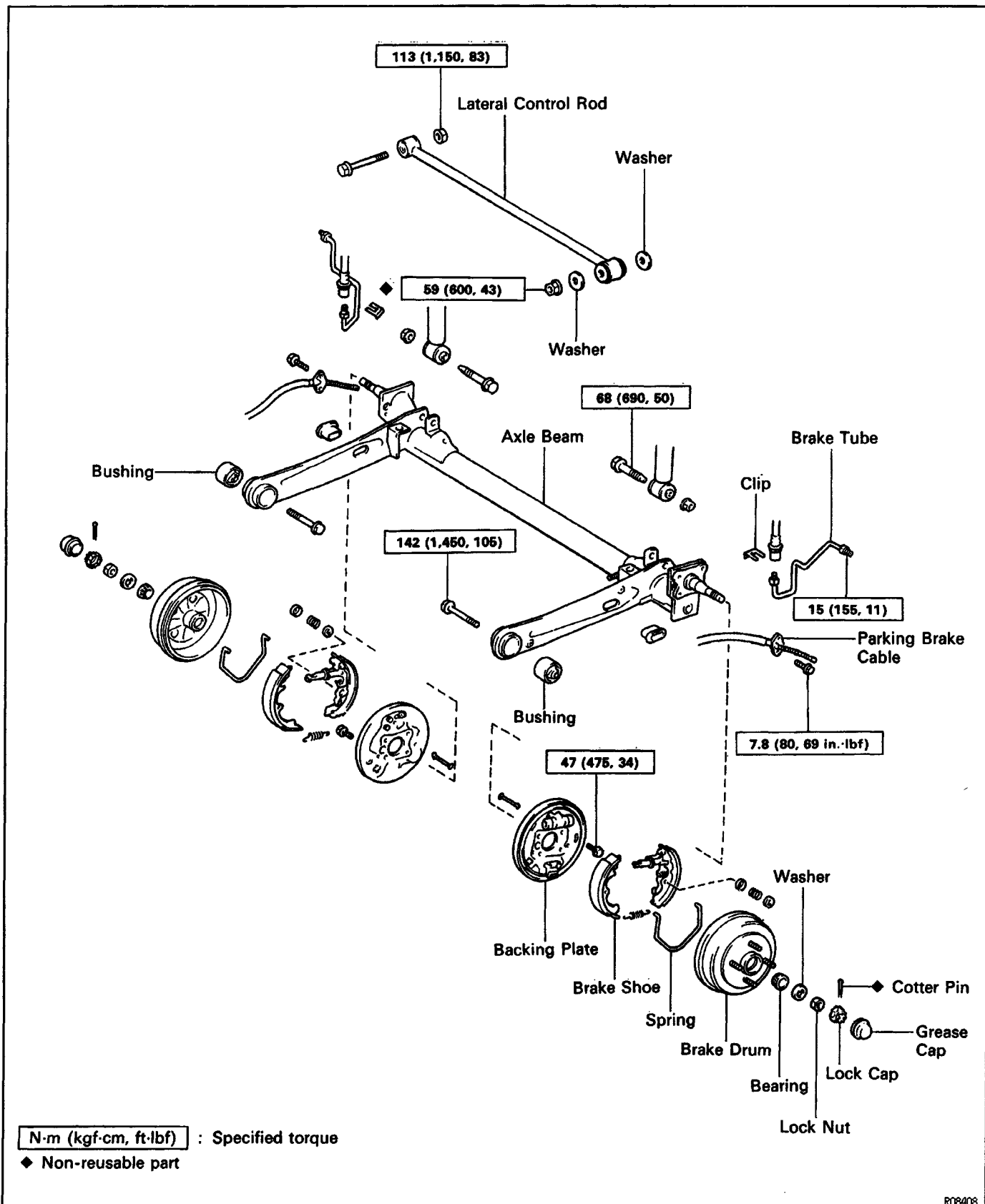

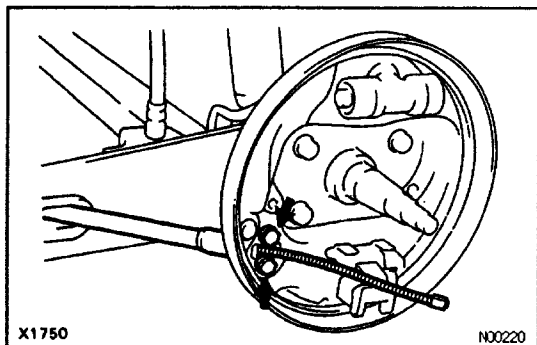

AXLE BEAM REMOVAL

1. REMOVE LEFT AND RIGHT AXLE HUBS

(See page SA-41)

2. REMOVE LEFT AND RIGHT BRAKE SHOES

(See page BR-31)

3. DISCONNECT PARKING BRAKE CABLE FROM BACKING PLATE

Remove the 2 bolts and disconnect the parking brake cable from the backing plate.

4. DISCONNECT BRAKE TUBE

(a) Using SST, disconnect the brake tube from the brake cylinder.

SST 09751-36011

(b) Remove the clip and disconnect the brake tube from the axle beam.

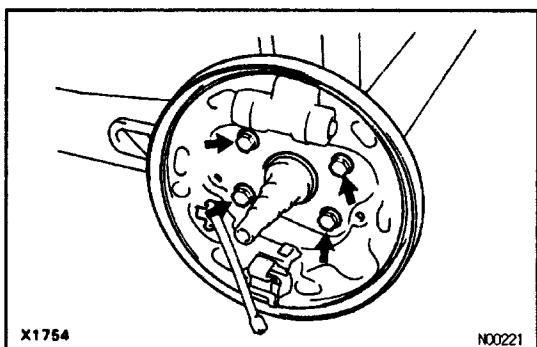
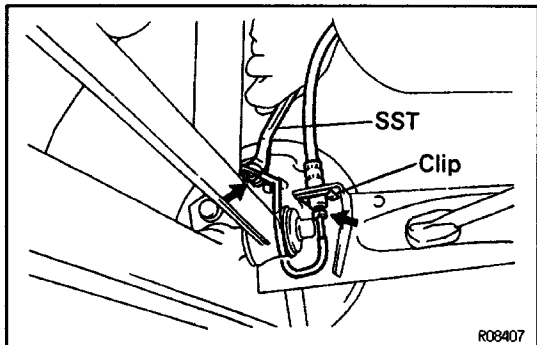

5. REMOVE BACKING PLATE

Remove the 4 bolts and the backing plate.

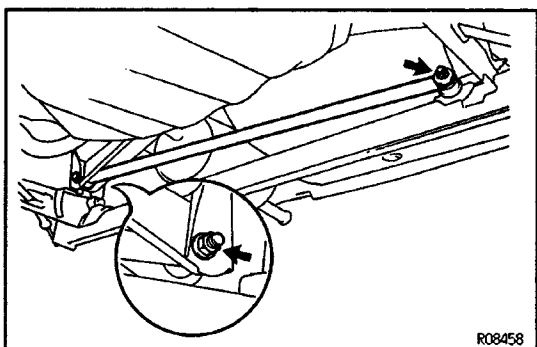

6. REMOVE LATERAL CONTROL ROD

(a) Remove the nut and bolt, disconnect the lateral control rod from the body.

(b) Remove the nut, washer and bushing.

(c) Remove the lateral control rod from the axle beam.

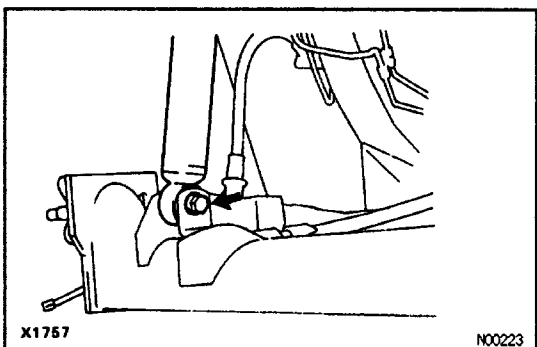

7. DISCONNECT SHOCK ABSORBER FROM AXLE BEAM

(a) Using a jack, support the axle beam.

(b) Remove the bolt and nut on lower side of the shock absorber.

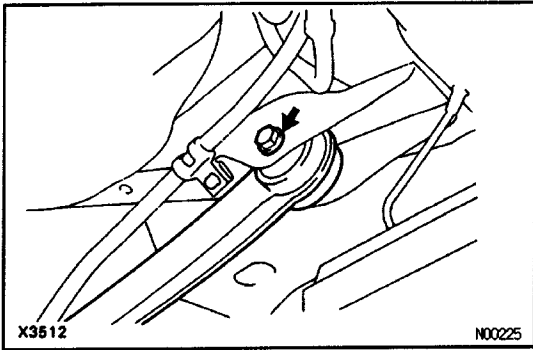

8. REMOVE AXLE BEAM

- (a) Remove the 2 bolts.
- (b) Remove the axle beam.

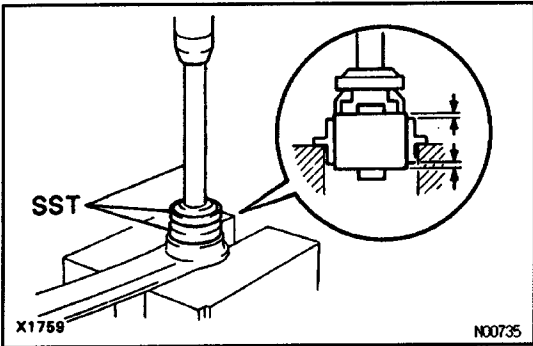

BUSHING REPLACEMENT REPLACE BUSHING

Using SST and a press, replace the bushing.
SST 09608-35014 (09608-06020, 09608-06030, 09608-06090)

HINT:

- Press the bushing in until it protrudes equally on the left and right sides.
- Install the bushing with protruding part forward, as shown in the illustration.

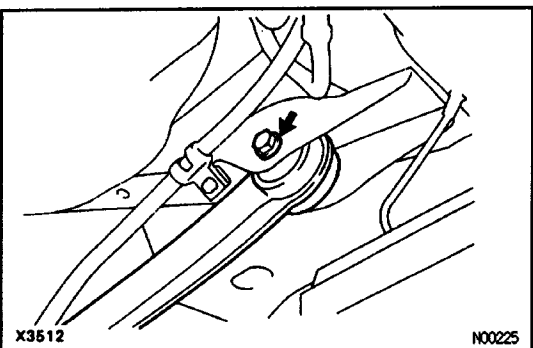
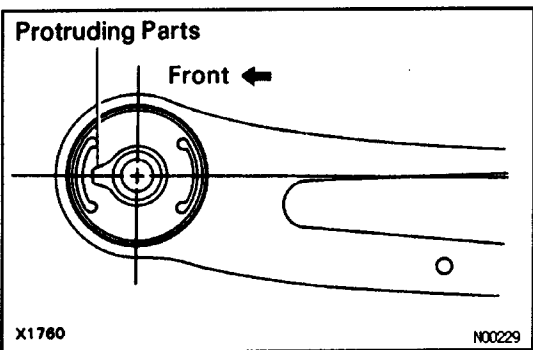

AXLE BEAM INSTALLATION

1. INSTALL AXLE BEAM

- (a) Place the axle beam.
- (b) Temporarily install the 2 bolts.

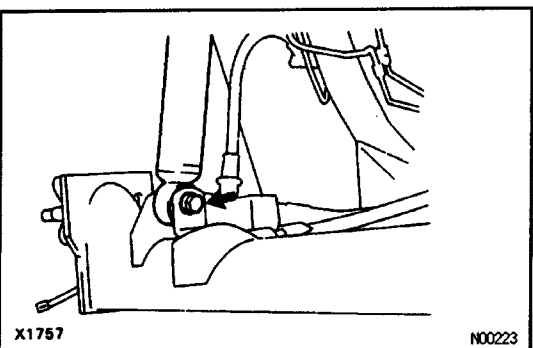

2. CONNECT SHOCK ABSORBER TO AXLE BEAM

Install the bolt and temporarily install the nut.

SA01H-02

SA01J-06

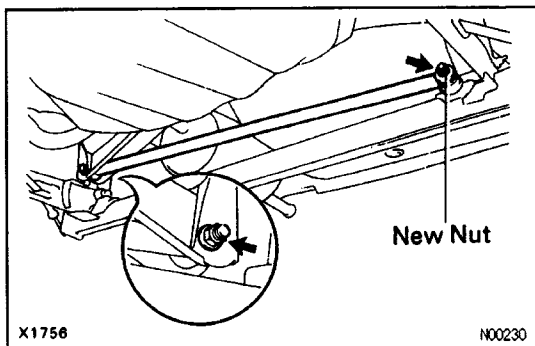

3. INSTALL LATERAL CONTROL ROD

- (a) Install the lateral rod to the axle beam with the bushings and washer.
- (b) Temporarily install a new nut.
- (c) Connect the lateral control rod to the body and temporarily install the bolt and nut.

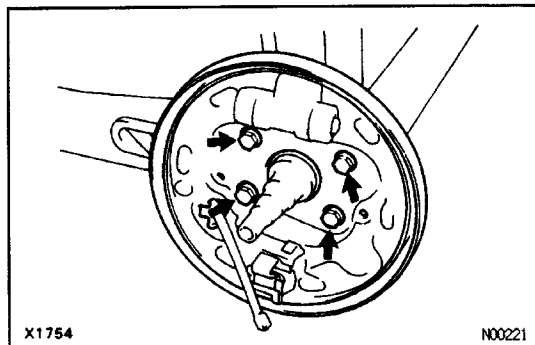

4. INSTALL BACKING PLATE

Install the backing plate with the 4 bolts.

Torque: 47 N-m (475 kgf-cm, 34 ft-lbf)

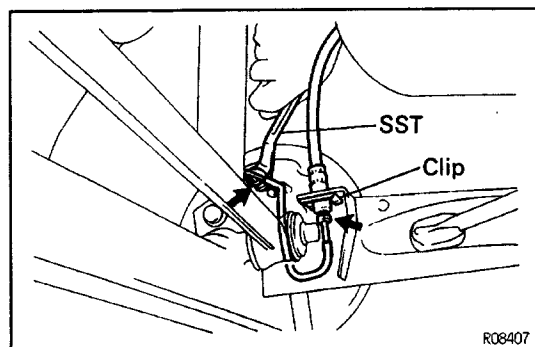

5. CONNECT BRAKE TUBE

- (a) Connect the brake tube to the axle beam and install the clip.
- (b) Using SST, connect the brake tube to the brake cylinder.

SST 09751 -36011

Torque: 15 N-m (155 kgf-cm, 11 ft-lbf)

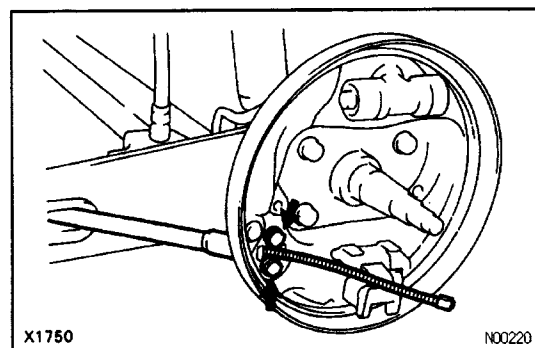

6. CONNECT PARKING BRAKE CABLE TO BACKING PLATE

Connect the parking brake cable and install the 2 bolts.

Torque: 7.8 N-m (80 kgf-cm, 69 in.-lbf)

7. INSTALL BRAKE SHOES

(See page [BR-35](#))

8. INSTALL AXLE HUB

(See page [SA-43](#))

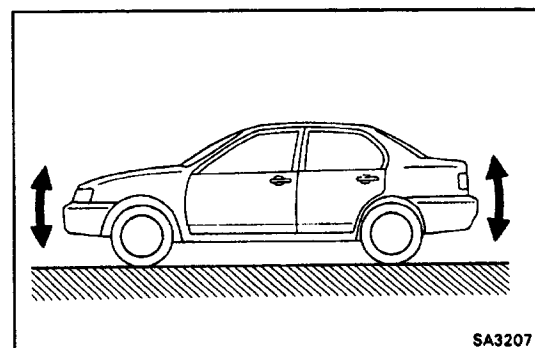

9. STABILIZE SUSPENSION

Lower the vehicle and bounce it up and down several times to stabilize the suspension.

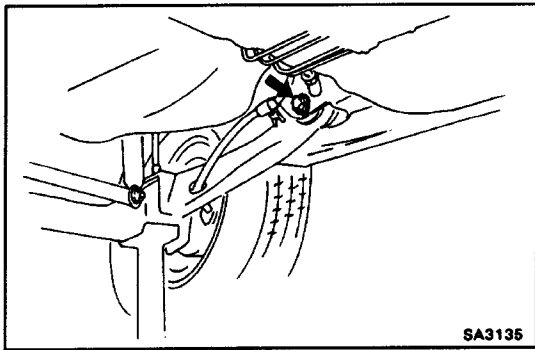

10. TORQUE BOLTS AND NUTS

(a) Jack up the vehicle and support the axle beam with stands.

(b) Torque the bolts of the axle beam.

Torque: 142 N-m (1,450 kgf-cm, 105 ft-lbf)

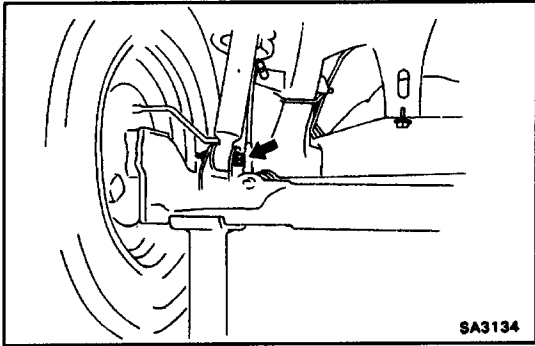

(c) Torque the nut on lower side of the shock absorber.

Torque: 68 N-m (690 kgf-cm, 50 ft-lbf)

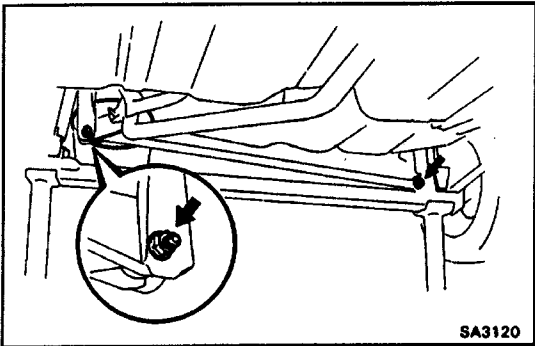

(d) Torque the nuts of the lateral control rod.

Body side

Torque: 113 N-m (1,150 kgf-cm, 83 ft-lbf)

Axle side

Torque: 59 N-m (600 kgf-cm, 43 ft-lbf)

(e) Lower the vehicle.

SERVICE SPECIFICATIONS

SERVICE DATA

SA01K-04

Cold tire inflation pressure	Tire size	Pressure kPa (kgf/cm ² , psi)	
		Front	Rear
	P145/80R13 155SR13 AS P155/80R13 AS	225 (2.25, 32)	225 (2.25, 32)
Vehicle height	Tire size	Height mm (in.)	
		Front	Rear
	P145/80R13	185(7.28)	248(9.76)
155SR13 AS P155/80R13 AS	192 (7.56)	255(10.03)	
Front wheel alignment	Toe-in (total)		$0.1^{\circ} \pm 0.2^{\circ}$ (1 ± 2 mm, 0.04 ± 0.08 in.)
	Camber		$-1' 5' \pm 45'$
	Caster		$1^{\circ} 15' \pm 45'$
	Steering axis inclination		$12^{\circ} 00' \pm 45'$
	Left-right error	Camber	45' or less
		Caster	45' or less
	Wheel angle	Inside	$36^{\circ} 10' \pm 2^{\circ}$
Outside		$32^{\circ} 15'$ (Reference)	
Rear wheel alignment	Toe-in		$0.3^{\circ} \pm 0.3^{\circ}$ (3 ± 3 mm, 0.12 ± 0.12 in.)
	Camber		$-0' 30' \pm 45'$
Front axle hub	Wheel bearing backlash		0.05 mm (0.0020 in.) or less
Front suspension	Lower ball joint turning torque		1.0 - 2.9 N-m (10 - 30 kgf-cm, 8.7 - 26 ft-lbf)
Rear axle hub	Bearing preload (turning)		Add frictional force plus 0-1 1.8 N (0-1.2 kg, 0-2.6 lb)

V04672

TORQUE SPECIFICATIONS (FRONT)

Part tightened	N-m	kgf-cm	ft-lbf
Disc brake dust cover x Steering knuckle	8.3	85	74 in.-lbf
Ball joint x Steering knuckle	98	1,000	72
Steering knuckle x Shock absorber	245	2,500	181
Ball joint x Lower arm	80	820	59
Tie rod end lock nut	49	500	36
Disc brake cylinder x Steering knuckle	88	900	65
Wheel bearing lock nut	216	2,200	159
Piston rod x Suspension support	47	475	34
Suspension support x Body	39	400	29
Brake hose x Shock absorber	29	300	22
Lower arm x Body (Front side)	142	1,450	105
Lower arm x Body (Rear side)	74	750	55
Hub nut	103	1,050	76

(REAR)

Part tightened	N-m	kgf-cm	ft-lbf
Piston rod x Suspension support	54	550	40
Suspension support x Body	39	400	29
Shock absorber x Axle beam	68	690	50
Backing plate x Axle beam	47	475	34
Parking brake cable x Backing plate	7.8	80	69 in.-lbf
Brake tube x Flexible hose	15	155	11
Brake tube x Wheel cylinder	15	155	11
Body x Axle beam	142	1,450	105
Lateral control rod x Axle beam	59	600	43
Lateral control rod x Body	113	1,150	83